

# **E1702S Slim Scanner Controller**

## **Users Manual**

© 2023-2026 by HALaser Systems GmbH

# Table of Contents

|            |  |    |
|------------|--|----|
| 1          | Copyright.....   | 4  |
| 2          | History.....   | 7  |
| 3          | Safety.....  | 9  |
| 4          | Overview.....  | 10 |
| 4.1        | Features.....  | 10 |
| 4.1.1      | E1702S XY2-100/XY3-100/NX-02 Digital Laser Scanner Controller Baseboard..... | 10 |
| 4.1.2      | E1702 Digi I/O Extension Board.....  | 11 |
| 4.1.3      | E1702 Secondary Head Extension Board.....                                    | 11 |
| 4.2        | E1701D / E1702S Comparison.....  | 11 |
| 5          | Position Within The System.....  | 12 |
| 6          | Boards And Connectors.....   | 13 |
| 6.1        | E1702S XY2-100/XY3-100 / NX-02 Slim Laser Scanner Controller Baseboard.....  | 13 |
| 6.1.1      | Ethernet.....  | 13 |
| 6.1.1.1    | Ethernet Configuration With Windows 10.....                                  | 14 |
| 6.1.1.2    | Ethernet Configuration With Windows 11.....                                  | 15 |
| 6.1.1.3    | Ethernet Configuration With Linux.....                                       | 15 |
| 6.1.2      | USB.....   | 16 |
| 6.1.3      | Power.....   | 17 |
| 6.1.4      | Power LED.....   | 17 |
| 6.1.5      | User LEDs.....   | 17 |
| 6.1.6      | Laser LEDs.....  | 18 |
| 6.1.7      | Reset-Button.....  | 18 |
| 6.1.8      | microSD-Card.....  | 18 |
| 6.1.8.1    | Firmware Update.....   | 25 |
| 6.1.9      | Laser/Scanner Signals.....   | 25 |
| 6.1.9.1    | XY2-100(E) Operation Mode.....   | 25 |
| 6.1.9.2    | XY3-100 Operation Mode.....  | 26 |
| 6.1.9.3    | NX-02 Operation Mode.....  | 27 |
| 6.1.9.4    | XY2-100 Connection Cable.....  | 27 |
| 6.1.9.5    | XY3-100 Connection Cable.....  | 28 |
| 6.1.10     | Extension Connectors.....  | 29 |
| 6.1.11     | Stand-Alone Operation.....   | 30 |
| 6.1.11.1   | Stand-Alone Operation with EPR files.....                                    | 30 |
| 6.1.11.1.1 | Create Stand-Alone EPR Data with BeamConstruct.....                          | 31 |
| 6.1.11.2   | Stand-Alone Operation with BEAMP files.....                                  | 32 |
| 6.1.11.3   | Stand-Alone Configuration Parameters.....                                    | 32 |
| 6.1.11.4   | Stand-Alone Control.....   | 35 |
| 6.2        | E1702 Digi I/O Extension Board.....  | 36 |
| 6.2.1      | Digi I/O.....  | 36 |
| 6.2.1.1    | Marking On-The-Fly Signals.....  | 38 |
| 6.2.2      | Opto-Configuration.....  | 39 |
| 6.2.3      | Input State LEDs.....  | 39 |
| 6.3        | E1702 Secondary Head Extension Board.....                                    | 40 |
| 6.3.1      | Scanner Signals.....   | 40 |
| 6.4        | E1702Sdock Extension Board.....  | 43 |
| 6.4.1      | E1702Sdock Connectors.....   | 43 |
| 6.4.2      | E1702Sdock Wiring.....   | 47 |
| 6.5        | E170Xbase.....   | 48 |
| 7          | Quick Start into E1702S.....   | 49 |
| 8          | Command Interface.....   | 50 |
| 8.1        | General Commands.....  | 50 |
| 8.2        | Stand-Alone Control Commands.....  | 51 |
| 8.2.1      | EPR specific commands.....   | 57 |
| 8.2.2      | BEAMP specific commands.....   | 57 |
| 8.3        | Hardware Commands.....   | 58 |
| 8.4        | Mark Control Commands.....   | 59 |
| 9          | Supported CNC G-Code Commands.....   | 67 |

|  |     |
|--|-----|
| 9.1 General G-Code Characters.....   | 67  |
| 9.2 Supported “G”-codes.....   | 67  |
| 9.3 Supported “M”-codes.....   | 69  |
| 9.4 Supported “T”-codes.....   | 71  |
| 9.5 Control Protocol.....  | 71  |
| 10 Programming Interfaces.....   | 73  |
| 10.1 E1702 Easy Interface Functions.....   | 73  |
| 10.1.1 Laser Port Specific Functions.....  | 90  |
| 10.1.2 Digital IO Functions.....   | 92  |
| 10.1.3 Stepper Motor Motion Functions.....   | 95  |
| 10.1.4 Miscellaneous functions.....  | 97  |
| 10.1.5 Writing of stand-alone data.....  | 98  |
| 10.1.5.1 Example.....  | 101 |
| 10.1.6 Error Codes.....  | 102 |
| APPENDIX A – Wiring between E1702S and specific laser types.....   | 104 |
| Wiring between E1702S and IPG YLP Series Type B, B1 and B2, GZTech YFPN series fiber laser.....  | 104 |
| Wiring between E1702S and JPT YDFLP series fiber laser (“MOPA”) or IPG YLP Series Type D fiber laser or Raycus RFL PMX/PQB Series fiber laser..... | 105 |
| Wiring between E1702S and IPG YLP Series Type E fiber laser.....   | 106 |
| Wiring between E1702S and IPG YLP Series Type F fiber laser.....   | 107 |
| Wiring between E1702S and Raycus fiber laser.....  | 108 |
| Wiring between E1702S and MaxPhotonics MFP fiber laser.....  | 109 |
| Wiring between E1702S and DAVI D-Series RF CO <sub>2</sub> Laser.....  | 110 |
| Wiring between E1702S and GZTECH S355 series DPSS Laser.....   | 111 |
| APPENDIX B – E1701D Compatibility Adaptor.....   | 112 |
| APPENDIX C – IDC connector pin numbering.....  | 114 |
| APPENDIX D – E1702S XY2-100 protocol description.....  | 115 |
| APPENDIX E – E1702S XY3-100 protocol description.....  | 116 |
| APPENDIX F – E1702S SL2-100 protocol description.....  | 117 |
| APPENDIX G – Board dimensions.....   | 118 |

# 1 Copyright

This document is © by HALaser Systems.

E1702 base- and extension boards, their hardware and design are copyright / trademark / legal trademark of HALaser Systems.

IPG and other are copyright / trademark / legal trademark of IPG Laser GmbH / IPG Photonics Corporation.

Scanlab, RTC4, RTC5, SL2-100 and other are copyright / trademark / legal trademark of Scanlab AG.

SCAPS, USC1, USC2 and other are copyright / trademark / legal trademark of SCAPS GmbH.

Raylase, SP-ICE, RL3-100 and other are copyright / trademark / legal trademark of Raylase AG.

Rofin, Rofin-Sinar, Visual Laser Marker and others are copyright / trademark / legal trademark of Raylase AG.

Sunny, CSC-USB and other are copyright / trademark / legal trademark of Beijing Century Sunny Technology CO., LTD

CTI, Cambridge Technology, Novanta and other are copyright / trademark / legal trademark of Novanta Inc.

Han's, Han's Laser and other are copyright / trademark / legal trademark of Han's Laser Technology Industry Group Co., Ltd.

All other names / trademarks are copyright / trademark / legal trademark of their respective owners.

## **Portions of the E1702 firmware are based on lwIP 1.4.0 (or newer):**

Copyright (c) 2001, 2002 Swedish Institute of Computer Science.

All rights reserved.

Redistribution and use in source and binary forms, with or without modification, are permitted provided that the following conditions are met:

- 1.Redistributions of source code must retain the above copyright notice, this list of conditions and the following disclaimer.
- 2.Redistributions in binary form must reproduce the above copyright notice, this list of conditions and the following disclaimer in the documentation and/or other materials provided with the distribution.
- 3.The name of the author may not be used to endorse or promote products derived from this software without specific prior written permission.

THIS SOFTWARE IS PROVIDED BY THE AUTHOR ``AS IS" AND ANY EXPRESS OR IMPLIED WARRANTIES, INCLUDING, BUT NOT LIMITED TO, THE IMPLIED WARRANTIES OF MERCHANTABILITY AND FITNESS FOR A PARTICULAR PURPOSE ARE DISCLAIMED. IN NO EVENT SHALL THE AUTHOR BE LIABLE FOR ANY DIRECT, INDIRECT, INCIDENTAL, SPECIAL, EXEMPLARY, OR CONSEQUENTIAL DAMAGES (INCLUDING, BUT NOT LIMITED TO, PROCUREMENT OF SUBSTITUTE GOODS OR SERVICES; LOSS OF USE, DATA, OR PROFITS; OR BUSINESS INTERRUPTION) HOWEVER CAUSED AND ON ANY THEORY OF LIABILITY, WHETHER IN CONTRACT, STRICT LIABILITY, OR TORT (INCLUDING NEGLIGENCE OR OTHERWISE) ARISING IN ANY WAY OUT OF THE USE OF THIS SOFTWARE, EVEN IF ADVISED OF THE POSSIBILITY OF SUCH DAMAGE.

## **Portions of the E1702 firmware are based on FatFS R0.10a (or newer):**

FatFs module is an open source software to implement FAT file system to small embedded systems. This is a free software and is opened for education, research and commercial developments under license policy of following terms.

Copyright (C) 2014, ChaN, all right reserved.

- The FatFs module is a free software and there is NO WARRANTY.
- No restriction on use. You can use, modify and redistribute it for personal, non-profit or commercial product UNDER YOUR RESPONSIBILITY.
- Redistributions of source code must retain the above copyright notice.

**Portions of the E1702 firmware are based on StarterWare 2.0 (or newer):**

Copyright (C) 2010 Texas Instruments Incorporated - <http://www.ti.com/>

Redistribution and use in source and binary forms, with or without modification, are permitted provided that the following conditions are met:

- Redistributions of source code must retain the above copyright notice, this list of conditions and the following disclaimer.
- Redistributions in binary form must reproduce the above copyright notice, this list of conditions and the following disclaimer in the documentation and/or other materials provided with the distribution.
- Neither the name of Texas Instruments Incorporated nor the names of its contributors may be used to endorse or promote products derived from this software without specific prior written permission.

THIS SOFTWARE IS PROVIDED BY THE COPYRIGHT HOLDERS AND CONTRIBUTORS "AS IS" AND ANY EXPRESS OR IMPLIED WARRANTIES, INCLUDING, BUT NOT LIMITED TO, THE IMPLIED WARRANTIES OF MERCHANTABILITY AND FITNESS FOR A PARTICULAR PURPOSE ARE DISCLAIMED. IN NO EVENT SHALL THE COPYRIGHT OWNER OR CONTRIBUTORS BE LIABLE FOR ANY DIRECT, INDIRECT, INCIDENTAL, SPECIAL, EXEMPLARY, OR CONSEQUENTIAL DAMAGES (INCLUDING, BUT NOT LIMITED TO, PROCUREMENT OF SUBSTITUTE GOODS OR SERVICES; LOSS OF USE, DATA, OR PROFITS; OR BUSINESS INTERRUPTION) HOWEVER CAUSED AND ON ANY THEORY OF LIABILITY, WHETHER IN CONTRACT, STRICT LIABILITY, OR TORT (INCLUDING NEGLIGENCE OR OTHERWISE) ARISING IN ANY WAY OUT OF THE USE OF THIS SOFTWARE, EVEN IF ADVISED OF THE POSSIBILITY OF SUCH DAMAGE.

Copyright (c) 2008-2010 Texas Instruments Incorporated. All rights reserved.

Software License Agreement

Texas Instruments (TI) is supplying this software for use solely and exclusively on TI's microcontroller products. The software is owned by TI and/or its suppliers, and is protected under applicable copyright laws. You may not combine this software with "viral" open-source software in order to form a larger program.

THIS SOFTWARE IS PROVIDED "AS IS" AND WITH ALL FAULTS. NO WARRANTIES, WHETHER EXPRESS, IMPLIED OR STATUTORY, INCLUDING, BUT NOT LIMITED TO, IMPLIED WARRANTIES OF MERCHANTABILITY AND FITNESS FOR A PARTICULAR PURPOSE APPLY TO THIS SOFTWARE. TI SHALL NOT, UNDER ANY CIRCUMSTANCES, BE LIABLE FOR SPECIAL, INCIDENTAL, OR CONSEQUENTIAL DAMAGES, FOR ANY REASON WHATSOEVER.

This is part of AM1808 Sitaware USB Library and reused from revision 6288 of the Stellaris USB Library.

**Portions of the E1702 firmware are based on libzint-backend 2.0 (or newer):**

libzint - the open source barcode library, Copyright (C) 2008-2017 Robin Stuart <[rstuart114@gmail.com](mailto:rstuart114@gmail.com)>

Redistribution and use in source and binary forms, with or without modification, are permitted provided that the following conditions are met:

1. Redistributions of source code must retain the above copyright notice, this list of conditions and the following disclaimer.
2. Redistributions in binary form must reproduce the above copyright notice, this list of conditions and the following disclaimer in the documentation and/or other materials provided with the distribution.

3. Neither the name of the project nor the names of its contributors may be used to endorse or promote products derived from this software without specific prior written permission.

THIS SOFTWARE IS PROVIDED BY THE COPYRIGHT HOLDERS AND CONTRIBUTORS "AS IS" AND ANY EXPRESS OR IMPLIED WARRANTIES, INCLUDING, BUT NOT LIMITED TO, THE IMPLIED WARRANTIES OF MERCHANTABILITY AND FITNESS FOR A PARTICULAR PURPOSE ARE DISCLAIMED. IN NO EVENT SHALL THE COPYRIGHT OWNER OR CONTRIBUTORS BE LIABLE FOR ANY DIRECT, INDIRECT, INCIDENTAL, SPECIAL, EXEMPLARY, OR CONSEQUENTIAL DAMAGES (INCLUDING, BUT NOT LIMITED TO, PROCUREMENT OF SUBSTITUTE GOODS OR SERVICES; LOSS OF USE, DATA, OR PROFITS; OR BUSINESS INTERRUPTION) HOWEVER CAUSED AND ON ANY THEORY OF LIABILITY, WHETHER IN CONTRACT, STRICT LIABILITY, OR TORT (INCLUDING NEGLIGENCE OR OTHERWISE) ARISING IN ANY WAY OUT OF THE USE OF THIS SOFTWARE, EVEN IF ADVISED OF THE POSSIBILITY OF SUCH DAMAGE.





### 3 Safety

The hardware described within this document is designed to control a laser scanner system. Laser radiation may effect a person's health or may otherwise cause damage. Prior to installation and operation compliance with all relevant safety regulations including additional hardware-controlled safety measures has to be secured. The client shall solely be responsible to strictly comply with all applicable and relevant safety regulations regarding installation and operation of the system at any time.

Beside of that some laser equipment can be damaged in case it is controlled with wrong signals or signals outside a given specification. Thus it is highly recommended to check the output generated by this hardware using e.g. an oscilloscope to avoid problems caused by wrong configurations. This should be done prior to putting a system into operation for the first time, whenever some parameters have been changed or whenever any kind of software update was installed.

The hardware described here is shipped without any cover and without prefabricated equipment for electric installation. It is intended to be integrated in machines or other equipment. It is not a device for use "as is", but a component which is intended to be used as part of a larger device, e.g. for integration in a machine with own housing or within an electrical cabinet. Prior to operation compliance with all relevant electric / electromagnetic safety regulations including additional hardware-controlled safety measures has to be secured. The client shall solely be responsible to strictly comply with all applicable and relevant regulations regarding installation and operation of the system at any time.

The hardware described here is an electrostatic sensitive device. This means it can be damaged by common static charges which build up on people, tools and other non-conductors or semiconductors. To avoid such a damage, it has to be handled with care and including all relevant procedures (like proper grounding of people handling the hardware, shielding/covering to not to let a person touch the hardware unwanted, proper packaging in ESD-bags, ...). For more information please refer to related regulations and standards regarding handling of ESD devices. The EMC Directive (2014/30/EU) does not apply to this hardware as it is not intended for an end user (a person without knowledge of EMC) and as it is not otherwise made available on the market.

The Low Voltage Directive (2014/35/EU) does not apply to this hardware as the voltage supply is below the 50V AC / 75V DC limit.

This document describes the E1702-hardware but may contain errors or may be changed without further notice.

# 4 Overview

This document describes the E1702S modular scanner controller which consists of E1702S XY2-100/XY3-100/NX-02 scanner controller baseboard plus optional extension boards.

The E1702S scanner controller board is designed for controlling galvanometric scanner systems with two axes. Depending on the used extension boards (which are optional) they also supply extensive signals for external control. The communication between the host system and the controller boards is done via Ethernet or USB.

When using E1702 series scanner controller boards, there is always one baseboard required for proper operation. This baseboard can be used together with different extension boards that provide additional signals for controlling the laser marking process. These extension boards are optional and have to be used only in environments where the additional signals processed by these boards are required. So depending on used type of laser and requirements, the minimal solution to control a laser marking system may consist of the baseboard only.

Normally extension boards can be combined with any baseboard and all other extension boards freely, there are no restrictions for usage. In case some specific extension board types can't be operated with other boards, this is stated in description of the related boards below.

Normally an E1702 baseboard can be combined with several extension boards of different types but not with more than one board of same type. In case of special extension boards where more than one board of the same type can be used, this is stated in description of the related board below.

## 4.1 Features

Following the features of available base- and extension boards are described

### 4.1.1 E1702S XY2-100/XY3-100/NX-02 Digital Laser Scanner Controller Baseboard

This baseboard can be used to control 2D scanheads that come with a XY2-100, XY2-100-E, XY3-100 or NX-02 interface, and lasers that are controlled via PWM and/or LP8 parallel interface. It can be combined with extension boards without any restrictions. E1702S offers following features:

- XY2-100 interface to scanhead with X and Y channel
- XY2-100-E interface to scanhead with X and Y channel
- XY3-100 interface to scanhead with X and Y channel
- NX-02 interface to scanhead with X and Y channel
- 100 Mbit Ethernet connection
- USB 2.0 connection
- wide-range 9..30V power supply
- online XY grid correction with support for several correction table file formats (like SCAPS™ .ucf, Scanlab™ .ctb and .ct5, Raylase™ .gcd, Rofin™ .fcr, Han's™ .crt, CTI™ .xml or Sunny™ .txt)
- high-definition online XY grid correction with BeamConstruct HD correction files (.bco)
- fast switching between up to 16 preloaded grid correction tables
- 10 microseconds vector cycle time and resolution (microstep period)
- command execution time down to 0,5 microseconds
- realtime processing of laser and scanner signals
- 26 bit internal resolution (for better quality also with 16 or 18 bit hardware output)
- two laser CMOS digital outputs for usage with YAG, CO2, IPG(tm) and compatible laser types (outputs can provide PWM frequency, Q-Switch, FPK-pulse, CW/continuously running frequency, stand-by frequency) running with frequencies of up to 20 MHz
- LP8 8 bit CMOS level parallel digital output e.g. for controlling laser power
- LP8 latch CMOS level digital output for usage with IPG(tm) and compatible laser types
- Main Oscillator CMOS level digital output for usage with IPG(tm) and compatible laser types
- 512 MByte DDR3 RAM
- 1 GHz CPU clock
- support for microSD and microSDHC cards
- internal command and vector data list with more than 17 million entries
- continuous list concept, no need to swap between buffers

- BeamConstruct PRO license included

#### 4.1.2 E1702 Digi I/O Extension Board

This board provides additional digital in- and outputs for synchronisation and communication with external equipment. It offers following features:

- 8 freely usable digital outputs providing either CMOS level or electrically insulated outputs via external power supply
- 8 freely usable digital inputs expecting either CMOS level or electrically insulated inputs via external power supply
- 2 digital inputs usable for quadrature encoder signals for marking on-the-fly applications

#### 4.1.3 E1702 Secondary Head Extension Board

Using boards of this type additional heads can be connected which then work fully parallel to the first scanhead of E1702S baseboard. As output-only device it provides an additional XY2-100(-E), XY3-100 or NX-02 connection.

### 4.2 E1701D / E1702S Comparison

Both, the E1701D scanner controller card and the E1702S controller are quite similar but differ in some specific points making the E1702S more suitable for a majority of applications. Following overview shows the major differences between both:

| Feature                              | E1701D Digital Scanner Controller Card | E1702S Slim Scanner Controller Card           |
|--------------------------------------|--|---|
| Power supply                         | Via USB or external 5V via power jack  | Via USB or external 9..30V via 2,54 mm header |
| Support of 3D Marking                | In XY2-100 mode only                   | Not supported                                 |
| LP8/MO/Latch signals for MOPA lasers | Requires separate LP8 extension board  | Supported                                     |
| 0..5V analogue output                | 1x, parallel to LP8 signal             | Not supported                                 |
| Dedicated pilot laser signal         | Not supported                          | Supported                                     |
| XY3-100 backchannel                  | Supported                              | Not supported                                 |
| NX-02 scanner protocol               | Not supported                          | Supported                                     |

## 5 Position Within The System

The E1702 scanner controller system can be connected to the host via Ethernet or USB to receive laser marking data from BeamConstruct laser marking application or from any other application which makes use of one of the provided programming possibilities (as described below). When using Ethernet connection, it optionally can be connected via USB too. In this case USB connection is used to retrieve BeamConstruct PRO license from the board:

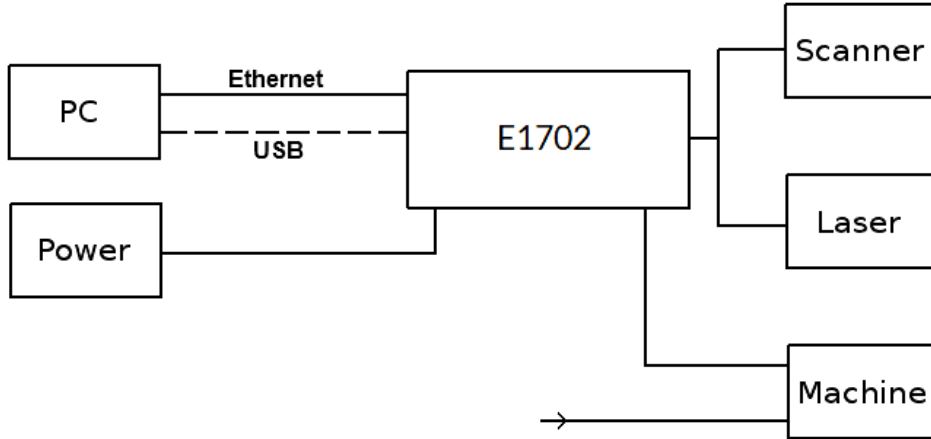

Since 100 Mbit Ethernet provides much faster data transfer than USB 2.0, this connection type is preferred. Especially in case complex marking data with many short lines that result in many separate jump and mark commands are used, Ethernet connection is more responsive.

When using USB connection with such data, time from sending data to the card until marking operation can be started may be longer (up to several seconds in worst case) caused by slower USB data transfer:

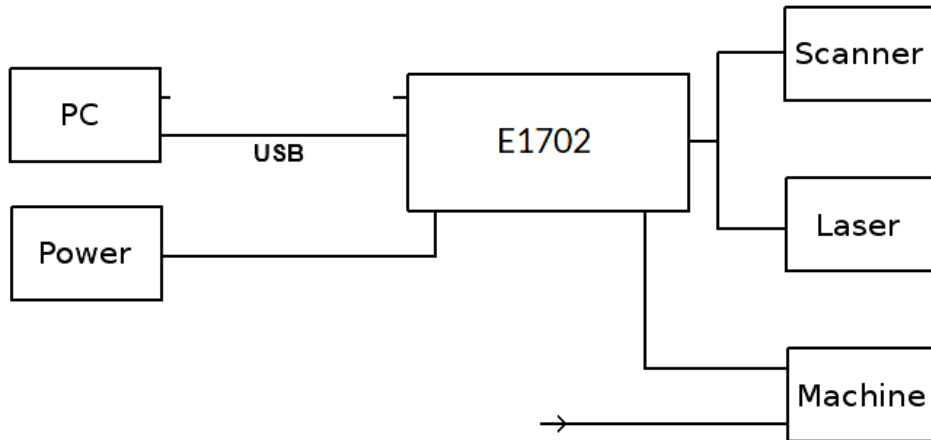

In both cases the board itself is connected with the scanhead to submit 2D position information to it. Beside of that, it is connected to a laser to submit motion-synchronous laser data. Additional communication channels between the E1702 scanner controller board and a connected machine can be done via separate IOs of an extension board.

## 6 Boards And Connectors

### 6.1 E1702S XY2-100/XY3-100 / NX-02 Slim Laser Scanner Controller Baseboard

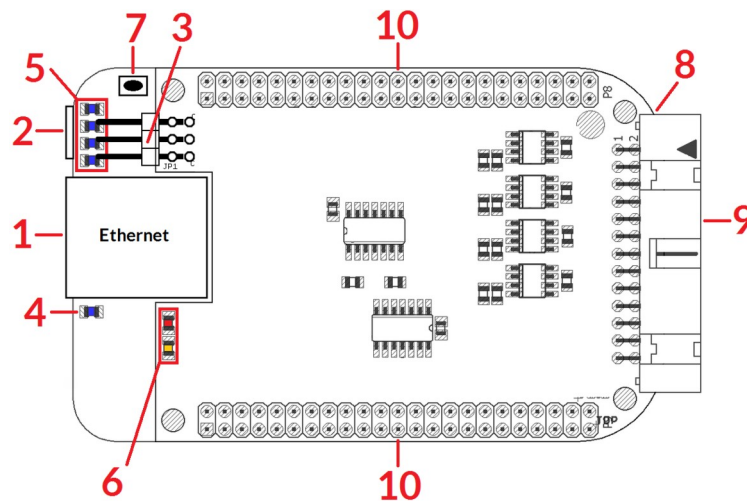

The E1702S Slim Laser Scanner Controller Baseboard provides following connectors and interfaces:

1. Ethernet – for communication with the host system, marking information are submitted via this path
2. USB – via microUSB connector for providing BeamConstruct PRO license to host system and optionally for submitting marking data from host to E1702S card (in case Ethernet is not used)
3. Power – connect with 6-pin header supplying power in range 9..30 V
4. Power LED – lights when power is available
5. User LEDs – show operational and error states of card
6. Laser LEDs– shows state of laser control signals
7. Reset-button – on-board button to restart the board completely
8. microSD-card (on bottom side) – storage place for firmware and extended configuration file, can be used to upgrade firmware, to change the card's IP and other things more
9. Laser/Scanner signals – white 26 pin laser and scanner output connector which provides XY2-100 / XY2-100-E / XY3-100 / NX-02 scanner signals as well as laser and marking control IOs
10. Extension connectors – extension boards can be placed here in order to add some more functionality and hardware interfaces to the board

#### 6.1.1 Ethernet

This is a standard RJ45 Ethernet plug for connection of the board with the host system. When the controller board is accessed via this connection, all scanner and laser data are sent via Ethernet. Thus it is recommended for security reasons to have a separate machine network that contains the control-PC, the scanner controller card(s) and other Ethernet-devices for the machine, but has no physical connection to the “outer world”, means no access to the internet.

Ethernet connection is initialised during start-up only, thus Ethernet cable connecting E1702 board and host system needs to be plugged before the board is powered up.

By default the E1702 baseboard is using IP 192.168.2.254, thus the Ethernet network the card is connected with needs to belong to subnet 192.168.2.0/24.

 PLEASE NOTE: For security reasons it is highly recommended to not to mix a standard communication network with an E1702 network or to connect the scanner controller card with a standard network. Here it may be possible someone else in that network (accidentally) connects to that scanner controller and causes laser emission.

The IP of the scanner controller can be changed. This is necessary e.g. in case an other subnet has to be used or in case the E1702 board has to be operated in multi-head environments where more than one card will be

accessed at the same time. The IP can be configured using e1702.cfg configuration file that is placed on microSD-card. To change the IP please perform the following steps:

1. disconnect E1702 board from power and USB
2. remove microSD-card
3. put microSD-card into a desktop computer, this may require a microSD- to SD-card-adapter
4. open the drive that is assigned to the card
5. open file e1702.cfg using a text editor like Notepad or kwrite
6. add a line or edit an existing line "ip0=", here the desired IP has to be appended (as example: when you want to configure IP 192.168.2.13 the line has to be "ip0=192.168.2.13" - without any quotation signs
7. save the file
8. eject the drive the card is assigned to
9. place the microSD-card in E1702 board (place without the use of force, notice correct orientation with connectors of microSD-card to bottom!)
10. power up card

When User LEDs do not light up as described below, please check if microSD-card is placed in board correctly.

### 6.1.1.1 Ethernet Configuration With Windows 10

When E1702 scanner controller is accessed via Ethernet, it is recommended to have a separate network for security reasons. Since the controller is working with a static IP (default is 192.168.2.254) the Ethernet port on host PC has to be configured with an IP of same subnet in order to allow access to it. For Windows 10 (and similar) this configuration has to be done using following steps:

1. right-click the network-symbol in your taskbar
2. Select "Open network and internet settings"
3. Select "Ethernet" on the left
4. find the network interface E1702 has to be connected with and select it
5. Click the "Edit" button in section "IP settings"
6. now a window opens where "IPv4" has to be turned on and that has to be configured as follows:

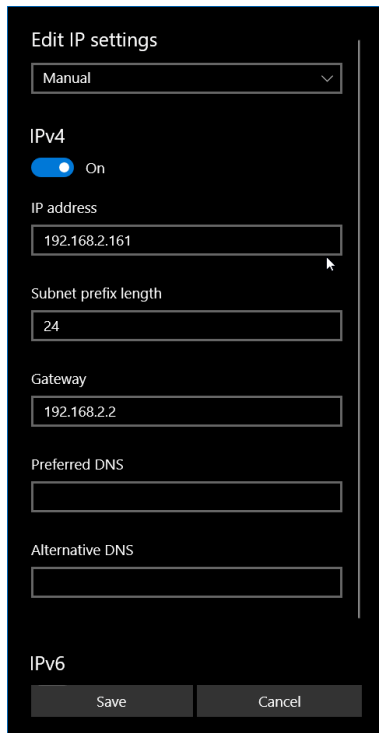

There you can specify an IP for your host PC. It has to belong to network 192.168.2.xxx and can be any number except than 192.168.2.254 (this is already the IP of the scanner card), 192.168.2.0 or 192.168.2.255.

### 6.1.1.2 Ethernet Configuration With Windows 11

When E1702S scanner controller is accessed via Ethernet, it is recommended to have a separate network for security reasons. Since the controller is working with a static IP (default is 192.168.2.254) the Ethernet port on host PC has to be configured with an IP of same subnet in order to allow access to it. For Windows 11 (and similar) this configuration has to be done using following steps:

1. right-click the network-symbol in your taskbar
2. Select "Network and internet settings"
3. Select "Ethernet" in the opened list
4. find the network interface E1702S has to be connected with and select it
5. Click the "Edit" button right beside "IP assignment"
6. now a window opens where "Edit IP Settings" has to be switched from "Automatic (DHCP)" to "Manual"
7. next "IPv4" has to be turned on and the remaining parameters in this window have to be configured as follows:

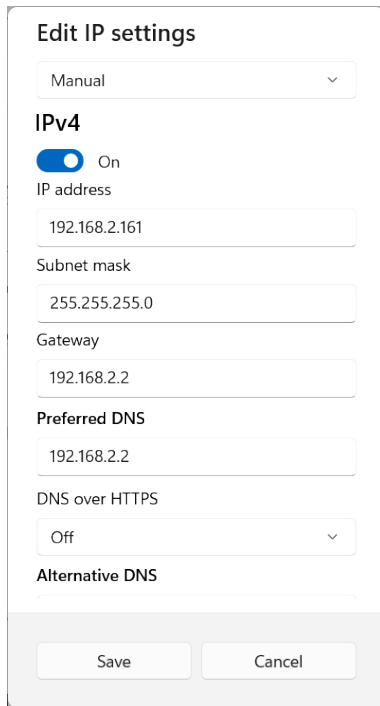

There you can specify an IP for your host PC. It has to belong to network 192.168.2.xxx and can be any number except than 192.168.2.254 (this is already the IP of the scanner card), 192.168.2.0 or 192.168.2.255.

### 6.1.1.3 Ethernet Configuration With Linux

When E1702 scanner controller is accessed via Ethernet, it is recommended to use a separate network for security reasons. Since the controller is working with a static IP (default is 192.168.2.254) the Ethernet port on host PC has to be configured with an IP of same subnet in order to allow access to it. For Linux (with NetworkManager) this configuration has to be done using following steps:

1. right-click the network-symbol in taskbar
2. click "Edit Connections..."
3. select the "Wired" network interface the scanner card is connected with and press button "Edit"

4. go to tab-pane "IPv4 Settings" and configure it as shown below:

The screenshot shows the 'Editing Auto eth0' window with the following configuration:

- Connection name: Auto eth0
- Connect automatically
- Available to all users
- Method: Manual
- Addresses table:

| Address       | Netmask       | Gateway |
|---------------|---------------|---------|
| 192.168.2.117 | 255.255.255.0 | 0.0.0.0 |
- DNS servers: [empty]
- Search domains: [empty]
- DHCP client ID: [empty]
- Require IPv4 addressing for this connection to complete

There you can specify an IP for your host PC. It has to belong to network 192.168.2.xxx and can be any number except than 192.168.2.254 (this is already the IP of the scanner card), 192.168.2.0 or 192.168.2.255.

## 6.1.2 USB

This is a standard microUSB-connector for connection of the board with the host system. It is used to retrieve BeamConstruct PRO license and optionally – when Ethernet is not connected – to send marking data to the card.



PLEASE NOTE: USB 2.0 is much slower than a standard 100 Mbit Ethernet connection, so expect slower execution in case of complex marking data!

Required device driver is installed together with installation of the HALsetup software package (Windows) or comes with operating system by default (Linux). E1702 card appears as COM-interface on Windows using any free number for the port. With Linux it appears as /dev/ttyACMx where "x" is any number. These numbers are provided by the operating system automatically.

By default USB provides 5V power supply too. So whenever card has to be stopped, both USB and power have to be disconnected in order to shut it down completely. It is not recommended to use USB as power supply, an additional, external power should be connected in order to operate E1702 controller correctly. Nevertheless it might be possible E1702 card can be operated on USB power only. Since this highly depends on the capabilities of used host system, it has to be evaluated for every particular case.

When the controller is connected via USB, a BeamConstruct PRO license is provided via this interface automatically. This is done without the need to configure anything, and as long as following conditions are true:

- physical USB connection from controller to host PC exists
- the COM-port (Windows) has a number smaller than COM20
- the controller is working and the Alive-LED in blinking

It is also possible to have the USB-connection for license retrieval only and to use the Ethernet-connection to transfer marking data to the controller, both can exist beside each other.

### 6.1.3 Power

Power supply for E1702S scanner controller board is done via 6 pin header on upper left corner of the board. Here pairs of pins belong to same power level. An appropriate fuse for circuit protection must be provided by the external equipment:

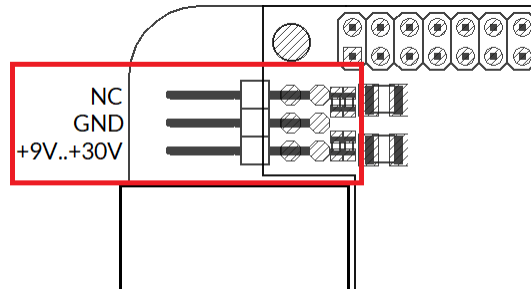

Power has to be supplied via this connector by connecting to a unipolar power supply with a voltage in range from 9V to 30V DC, max +/- 0.15V tolerance and 1.5A (stabilised and smoothed). Do not apply voltages in excess of 30V or with inverted polarity to this input. The DC power supply must be grounded.

To avoid high frequency interferences from other electrical equipment or from within the power supply, it is recommended to place a ferrite bead at the cable close to the board. Please also check for correct shielding in respect to the equipment the E1702S card is used within.

 **ATTENTION:** due to the undefined behaviour of some power supplies with high peaks in some specific situations, the power to the controller never should be toggled just by pulling and reconnecting a cable which is on power (hot-swap). Always turn off the power the regular way via the power supplies input/a regular switch. Otherwise this can cause serious damage to the controller card or power supply.

### 6.1.4 Power LED

This LED is lit as soon as the board is on some power. This means it may be functional and could emit any signals as soon as this LED is on but it does not necessarily need to work properly since firmware may not be started yet. Please refer section below for LEDs that show functional state of the board.

### 6.1.5 User LEDs

The real operational state of the card is shown by four additional LEDs described here from inner to outer position:

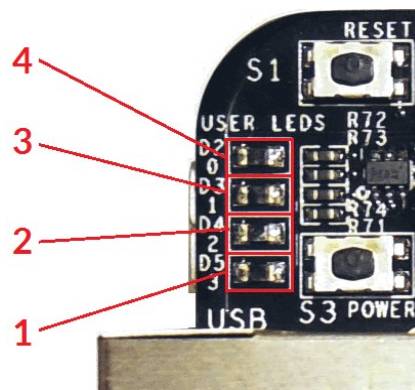

1. Boot- and Alive-LED – this LED is turned on permanently as soon as the card was powered up and the firmware boots properly. When it is not turned on after some seconds, please check if the microSD-card is placed properly and if it contains a working firmware file (for details please refer below). After boot process has completed successfully, it starts blinking slowly. This is an alive-notification, as long as it blinks, the board is working and ready for operation. During marking operations the blink frequency may change. Only in case it does not blink for more than 20 seconds, the board has died for some reason and should be restarted.

Please note: during start-up and when no configuration parameter “eth=0” or “eth=1” is set in e1702.cfg, the blinking frequency can be much slower. This is the case as long as the controller tries to

detect an Ethernet connection. It ends and switches to faster blink frequency as soon as this detection is timed-out or as soon as a connection via Ethernet or USB is established.

2. Marking Active LED – this LED is turned on as long as a marking operation is running. This LED does not correspond to the laser gate signal, comparing to it it's also enabled during jumps when laser is turned off but marking operation itself is active.
3. Stop LED – this LED is lit as long as a valid external stop signal is detected.
4. Error-LED – this LED is turned on in case a fatal error occurs that normally should never happen. When it is on, in most cases board can't continue with operation until the reason for error is removed and the board is restarted. In case this LED is turned on please:
  - check if you are using exactly one baseboard
  - check if you are using E1702 extension boards only (and no other 3rd party hardware)
  - check if you are using latest firmware and host software
  - check all connections and cables
  - undo your latest changes in hardware and configurationIf these steps do not help, please contact HALaser Systems for further assistance.

### 6.1.6 Laser LEDs

These LEDs shows modulation state of the laser (signal of laser gate output) and the signal state of the main oscillator output.

Here the red LED is lit as long as the laser is turned on and the laser gate is HIGH. This LED does NOT signal the same like the marking active LED described above since it will be turned off during jumps.

The yellow LED is lit as long as the main oscillator output of the scanner/laser signal connector is at HIGH.

### 6.1.7 Reset-Button

When this button is pressed for at least 20 milliseconds, it restarts the card completely, a current marking operation is cancelled, all signals are disabled and all remaining marking data are dropped. After releasing this button, the board is rebooted and firmware is started again.

### 6.1.8 microSD-Card

The microSD card is the storage place for firmware and configuration files. Here SD and SDHC cards are supported.

To remove the microSD-card, first disconnect all power from the E1702 board completely (including USB, Power LED has to go off). Next press microSD card gently into the board until you can hear a click-noise. Then you can pull it out of the board. To place a microSD card, the same has to be done in reverse order: place it into the E1702 board's card slot and press it gently until a noise signals locking of the card. Now the board can be powered.

E1702 baseboard is shipped with a card containing firmware and configuration files:

- e1702.fwi – firmware file that is used to operate the board, to be replaced when a firmware update is provided
- e1702.cfg – configuration text file, can be edited using a text editor in order to modify cards configuration
- e1702.dat – additional data file that is used to operate the board, to be replaced when a firmware update is provided

To use an other microSD card than the one shipped with the board, following conditions have to be met:

- SD or SDHC card
- FAT32 formatted
- using only one partition
- BOOT-flag is set
- E1702.fwi and e1702.dat file available on card



The E1702.cfg file contains plain ASCII text, acts as configuration file and can contain several parameters and its values which are separated by an equal-sign. Every of the possible parameter/value pairs has to be located in an own line. Following configuration parameters are possible within this file:

| Parameter      | Description   | Example   |
|----------------|---|---|
| ip0            | Configures IP of Ethernet port. Here only IPs in xxx.xxx.xxx.xxx notation are allowed but no host or domain names.  | ip0=192.168.2.100<br>specifies IP 192.168.2.100 to be used for Ethernet interface on next startup   |
| corrtable0     | Specifies a correction table file in .ctb, .ct5, .ucf, .gcd, .xml, .crt, .txt, .fcr or .bco format to be loaded on start-up. When this parameter is set, the specified correction table is used exclusively and all correction data possibly sent from the host are ignored. The correction file itself has to be located on microSD-card too.<br>This method has also to be used when running the controller in stand-alone mode with .EPR files that require such a correction. When the Error-LED is turned on after a correction table file was configured, E1702 baseboard was not able to load it for some reason.  | corrtable0=0:/D2_200.ctb<br>use file D2_200.ctb as correction file and ignore all correction tables possibly sent from host application                       |
| corrtable<idx> | Specifies one of up to 16 correction table file in .ctb, .ct5, .ucf, .gcd, .xml, .crt, .txt, .fcr or .bco format to be loaded on start-up. When this parameter is set, the specified correction table is used exclusively and all correction data possibly sent from the host are ignored. The correction file itself has to be located on microSD-card too.<br>This method has also to be used when running the controller in stand-alone mode with .EPR files that require such a correction. When the Error-LED is turned on after a correction table file was configured, E1702 baseboard was not able to load it for some reason.<br><idx> can be any value in range 0..15 and specifies the storage location index of the correction file to be loaded. Later the related correction file can be used via command <code>cscor</code> .  | corrtable7=0:/200_200.bco<br>use file 200_200.bco as correction file at index position 7 and ignore all correction tables possibly sent from host application |
| passwd         | Specifies an access password that is checked when card is controlled via Ethernet connection. This password corresponds to password specified with function <code>E170X_set_password()</code> , please refer below for a detailed description.<br>When a client computer connects to the card without sending the correct password, Ethernet connection to this host is closed immediately.<br>PLEASE NOTE: this password does not replace any network security mechanisms and does <u>not</u> give the possibility to operate E1702 controller via insecure networks or Internet! It is transferred unencrypted and therefore can be "hacked" easily. Intention of this password is to avoid unintended collisions between several E1702 cards that operate in same network and are accessed by several software instances.<br>Maximum allowed length of the password is 48 characters. It is recommended to <u>not</u> to use any language-specific characters. | passwd=myCardPwd<br>set a password "myCardPwd"  |
| standalone     | This command can be used to disable or enable a specific stand-alone operation mode. For a detailed description of possible parameters, operation modes and usage please refer related section "6.1.11 Stand-Alone Operation" below.  |   |
| iolatch        | When using one of the digital-input-controlled stand-alone modes, this option can be used to latch the digital states in via DIn7 of the DigilO Extension Board. For details please refer to section "6.1.11 Stand-Alone Operation" below   | iolatch=1<br>enable the latch-function via DIn7   |



| Parameter          | Description   | Example  |
|--------------------|---|--|
| iothres            | <p>In stand-alone mode there are two conditions that cause a loaded EPR file to be ready: it is fully loaded into the secondary, marking buffer or a minimum amount of data is available in secondary buffer.</p> <p>Something similar is true for host-controlled operating mode: here marking starts when <code>E170X_execute()</code> is called or when a minimum amount of data has been transmitted to the controller.</p> <p>That minimum amount of marking data can be modified with the parameter "iothres". The smaller this value is, the faster marking will start, but in this case it also may happen there are not enough data available so that interruptions occur during marking. So a balance between speed and a secure, non-interrupted marking process need to be found when this value is modified.</p> <p>By default "iothres" is 80000 which should fit to most applications, the maximum allowed value is 280000 and it should not become smaller than 10000</p> | <pre>Iothres=120000</pre> <p>Set the threshold for availability of the stand-alone marking data to 120000</p>  |
| haltedloop timeout | <p>This parameter is used in stand-alone modes "haltedloop" and "iohaltedloop" (please refer to section "6.1.11 Stand-Alone Operation" for detailed information). It defines a timeout for the laser in unit seconds. If the current operation is active for a longer time, the laser is turned off. It then can be turned on only by toggling the enable-input (ExtStart) again.</p>   | <pre>haltedlooptimeout=5</pre> <p>sets the laser timeout to 5 seconds</p>  |
| haltedloop buffer  | <p>This parameter is used in stand-alone modes "haltedloop" and "iohaltedloop" (please refer to section "6.1.11 Stand-Alone Operation" for detailed information). It defines a maximum buffer size for the marking data. The buffer size should have a size of 17000000 at max. The minimum size depends on the specific application, in fact, when it is set to some too small values, drop-outs in marking operation may occur.</p> <p>Data which are already buffered in this marking mode can't be modified any longer. So any change on marking speed, power or similar (done e.g. by commands "cjsor", "cmsor" or "cpwor") will apply only to data which are not yet buffered. And as bigger as this buffer is, as longer it takes until the first new data after change of any of these parameters can be emitted.</p>   | <pre>haltedloopbuffer=100000</pre> <p>set the buffer to a maximum size of 100000 commands which is similar to data for about 1 second marking time</p>   |
| autofile           | <p>Loads a special .EPR or .BEAMP stand-alone file from SD-card in some specific stand-alone modes. For a detailed description of possible parameters, operation modes and usage please refer related section below.</p>  | <pre>autofile=0:/markdata.epr</pre> <p>loads a file markdata.epr from disk; here 0:/ specifies the SD-card to be used. The .EPR-file itself can be generated within BeamConstruct out of a normal .BEAMP project file.</p> |
| iobuff             | <p>Pre-loads one or more .EPR or .BEAMP files to the RAM of the controller to allow faster switching in "ioselect" or "idxselect" stand-alone mode. This command can not be used to load file "0.EPR"</p>   | <pre>iobuff=1 iobuff=3</pre> <p>pre-load files 1.EPR and 3.EPR on board start-up</p>   |
| mipout             | <p>Configure a Digi I/O output pin (requires the DigiI/O Extension Board) to be used as "mark in progress"-signal by default; here an output bit number in range 0..7 has to be configured which will be set to HIGH as long as a marking operation is in progress, the value given here can be overwritten by API-function <code>E170X_digi_set_mip_output()</code></p> <p>Starting with firmware version 4 it is also possible to use the LaserB pin as output. This requires the tune-flag 128 (0x80)</p>  | <pre>mipout=1</pre> <p>use DOut1 for mark-in-progress signal</p>   |

| Parameter    | Description  | Example   |
|--------------|--|---|
|              | being set and mipout being used with a value of 33.  |   |
| wetout       | Configure a Digi I/O output pin (requires the Digi I/O Extension Board) to be used as “wait for external trigger”-signal by default; here an output bit number in range 0..7 has to be configured which will be set to HIGH as long as a marking operation is in progress and the controller is waiting for an external trigger signal to arrive at ExtStart input, the value given here can be overwritten by API-function<br>E170X_digi_set_wet_output()<br>Starting with firmware version 4 it is also possible to use the LaserB pin as output. This requires the tune-flag 128 (0x80) being set and wetout being used with a value of 33. | wetout=0<br>use DOut0 for mark-in-progress signal                                     |
| digiinit     | Initialises the digital outputs of the Digi I/O Extension Board on firmware start-up with the given defaults. This overrides the hardware defaults. The default digital values set here are NOT available on power up but a few seconds later after firmware has been loaded and started.  | digiinit=2<br>set DOut1 to HIGH initially and all other outputs to LOW                |
| digimask     | Masks the digital inputs of the Digi I/O Extension Board and specifies which inputs can be read. All input bits which are ignored by this command by setting the related value to 0, are no longer read. This may be useful for applications where encoder inputs are used together with a IOSelect stand-alone operation and where the random state of the encoder has to be masked out.  | digimask=253<br>use only DIn2..DIn7 as input and ignore DIn0 and DIn1                 |
| digidebc     | Sets a debouncing time / filter time for the digital inputs of the Digi I/O Extension Board in order to not to let the inputs react on noise or bouncing of mechanical inputs. The debouncing value is given in time-units where every time-unit is equal to 31 usec. By default 7 time-units are set.   | digidebc=10<br>set the debounce-time to 310 usec                                      |
| lasergate    | By default, the laser on/off information is provided via the LaserGate output and with CMOS logic voltage level. With this parameter, a digital output of the Digi I/O extension board can be specified, to provide the laser gate signal in parallel. Please refer to “6.2 E1702 Digi I/O Extension Board” for further details about the digital interface.   | lasergate=3<br>Use DOut3 to provide the laser gate signal                             |
| tunereadyout | In stand-alone modes, the ready-state of a loaded stand-alone project is signalled via DOut0 by default (please refer to section “6.1.11.4 Stand-Alone Control” for further details). Using this parameter, the used output can be changed. Here following values can be given: <ul style="list-style-type: none"> <li>• 0 – DOut0 (Digi I/O Extension Board, default)</li> <li>• 1 – LaserA (has to be configured as GPO via the related tune-flag)</li> <li>• 2 – LaserB (has to be configured as GPO via the related tune-flag)</li> </ul>  | tunereadyout=1<br>use LaserA to signal state “ready” in stand-alone mode              |
| tunemarkout  | In stand-alone modes, the ready-state of a loaded stand-alone project is signalled via DOut1 by default (please refer to section “6.1.11.4 Stand-Alone Control” for further details). Using this parameter, the used output can be changed. Here following values can be given: <ul style="list-style-type: none"> <li>• 0 – DOut1 (Digi I/O Extension Board, default)</li> <li>• 1 – LaserA (has to be configured as GPO via the related tune-flag)</li> <li>• 2 – LaserB (has to be configured as GPO via the related tune-flag)</li> </ul>  | tunemarkout=2<br>use LaserB to signal state “ready” in stand-alone mode               |
| tune         | Enables special functions and features that are not activated by default. As parameter a number can be handed over that specifies the functions to be enabled. Optionally the number can   | tune=1<br>disables ExtStart input and switches over external trigger function to DIn7 |

| Parameter  | Description  | Example   |
|--|--|---|
| <br><br> | <p>also be specified as hexadecimal value when it is prefixed with "0x". Following numbers can be logically OR-concatenated (aka by adding their values):</p> <p>1 (0x01) – use DIn7 of Digi I/O Extension Board as external trigger, this disables ExtStart input of E1702 Baseboard</p> <p>2 (0x02) – use additional marking encoder inputs on DIn2 and DIn3 for 2D on-the-fly operations</p> <p>4 (0x04) – enable storage of serial number count values to microSD card; this option is useful in case of stand-alone operation mode when dynamic data with serial number counting is used. When it is set, the current count value of all used serial numbers is stored and reloaded on next power up. Thus their values are not get lost when power was turned off. The values are stored in a file with the same name like the "autofile" or the currently loaded .epf file but with extension ".ser".<br/> <b>ATTENTION:</b> The file is saved on the FatFS formatted microSD card. FatFS is NOT fault-proof, means it can be corrupted when power is turned off during writing. So when this option is enabled, user has to ensure power is NOT turned of while the card writes to disk. Writing of serial number states is always done in case they have changed, then it is started when state LED of E1702 board is switched off. Write operation is finished when this LED is turned back on the next time. So to ensure data are written successfully, it is recommended to let this LED blink two times after last mark operation has been finished. In automated environment this can be ensured by following procedure:</p> <ol style="list-style-type: none"> <li>1. stop all marking operations</li> <li>2. ensure no new marking operation is triggered</li> <li>3. wait for 2 seconds</li> <li>4. turn power off</li> </ol> <p><b>ATTENTION:</b> due to this limitation it is not recommended to work with this option but to save the state of the serial numbers by sending ASCII command "cssta" instead (please refer below for details)!</p> <p>8 (0x08) – invert LaserGate output to work as active HIGH signal; when this option is set, logic of LaserGate-LED changes too, it is on as long as laser is turned off and it is off as long as laser is on</p> <p>16 (0x10) – invert LaserA output to work as active HIGH signal</p> <p>32 (0x20) – invert LaserB output to work as active HIGH signal</p> <p>64 (0x40) – use LaserA output as GPO (general purpose output pin); when this flag is set, LaserA output is no longer able to emit a frequency but can be used as digital output pin; when this value is set, a tune-value of 0x10 (invert LaserA) is ignored. This flag has to be set e.g. when LaserA has to be used together with <code>tunereadyout</code> or <code>tunemarkout</code> parameter.</p> <p>128 (0x80) – use LaserB output as GPO (general purpose output pin); when this flag is set, LaserB output is no longer able to emit a FPK pulse but can be used as digital output pin; when this value is set, a tune-value of 0x20 (invert LaserB) is ignored. This flag has to be set e.g. when LaserA has to be used together with</p> | <p>input</p> <p><code>tune=0x1000</code></p> <p>force the acanner output to use XY2-100E mode</p> |

| Parameter   | Description  | Example   |
|---|--|---|
|   | <p>tunereadyout or tunemarkout parameter.</p> <p>4096 (0x1000) – operate in enhanced XY2-100 18 bit mode; when this value is added to the tune-parameter, the controller outputs more accurate 18 bit position data instead of the standard 16 bit values in normal operation mode</p> <p>8192 (0x2000) – operate in XY3-100 mode; when this value is added to the tune-parameter, the controller outputs more accurate position data instead of the standard 16 or 18 bit values in normal operation mode</p> <p>32768 (0x8000) – invert the mark-in-progress signal</p> <p>65536 (0x10000) – invert the wait-external-trigger signal</p> <p>524288 (0x80000) – inverts the logic of the ExtStop input; by default, the stop-input is LOW and has to be set to HIGH in order to stop a running operation. When this flag is set, this is inverted, ExtStop has to kept HIGH for normal operation and a stop is performed as soon as it goes to LOW.</p> <p>2097152 (0x2000000) – halt the current marking operation when ExtStart input is at LOW; with this tune-flag set, the ExtStart input not only reacts on the rising edge to mark when waiting for an external trigger, it also requires to be HIGH in order to continue marking. So ExtStart acts as some kind of “enable” input.</p> <p>4194304 (0x400000) – invert the LP8 signal</p> <p>8388608 (0x800000) – invert the MO (main oscillator) signal</p> <p>16777216 (0x1000000) – inverts the logic of the ExtStart input. By default, the start-input reacts on a rising edge. When this flag is set, this is inverted and a falling edge is expected to release an external trigger. This also has an effect on the behaviour of tune-flag 0x2000000, it is inverted too.</p> |   |
|  <p>sntp0</p> | <p>Allows to specify the IP of an SNTP time server. This option can be used in case of Ethernet usage to synchronise controller with an external time source. E1702 tries to connect to this server after initialisation of Ethernet interface and – if not successful – a few more times. These additional connection attempts are done whenever the Alive-LED is switched on.</p> <p>ATTENTION: when this function has to be used, the network or host-computer the controller is connected with needs to be able to route this request. This is a potentially dangerous operation because a connection between encapsulated machine network and open and dangerous Internet has to be established. Since this is NOT RECOMMENDED in general, this option should be used ONLY when it is 100% sure there is no possibility for people from outside to intrude the machine network! Instead of that it is recommended to set system time manually using host-computer and ASCII command "cstime" (please refer below). Alternatively it is also possible to contact an own, network-internal NTP-server.</p> <p>When this option is used, the gateway and netmask have to be configured for the controllers Ethernet interface</p>  | <p>sntp0=83.170.1.42 – IP of time server at 3.de.pool.ntp.org is used for SNTP time retrieval (not recommended since this requires a connection to potentially dangerous Internet!)</p> |

| Parameter   | Description  | Example   |
|-------------|--|---|
| sntp0offset | This value corresponds to sntp0 parameter above, it is used when system time is retrieved from an external time server to set an offset to the time returned from this server. The offset has to be specified in unit seconds.   | sntp0offset=-3600 - specifies an offset of minus one hour to the time returned from timeserver. So when the time server would return a current time of 11:42:17, the system time of the controller would be set to 10:42:17 with this value |
| gw0         | Specifies a gateway-address for the scanner controllers Ethernet interface. This option belongs to parameter "ip0" and has to be set in case "sntp0" is used.  | gw0=192.168.2.1 - use 192.168.2.1 as gateway  |
| nm0         | Specifies the netmask for the scanner controllers Ethernet interface. This option belongs to parameter "ip0" and has to be set in case "sntp0" is used.  | nm0=255.255.255.0 - use upper 24 bits of current IP for netmask   |
| node0       | Specifies the IP of an external HALnode Compact Ethernet IO module to be used for additional 8 digital in- and outputs (lower 8 bits of an additional 16-bit IO port). Once configured, the HALnode's digital ports are used as they were a part of the controller. This functionality requires firmware version 21 or newer.  | node0=192.168.1.253 - use the digital IOs of the HALnode at the IP 192.168.2.253  |
| node1       | Specifies the IP of an external HALnode Compact Ethernet IO module to be used for additional 8 digital in- and outputs (upper 8 bits of an additional 16-bit IO port). Once configured, the HALnode's digital ports are used as they were a part of the controller. This functionality requires firmware version 21 or newer.  | node1=192.168.1.252 - use the digital IOs of the HALnode at the IP 192.168.2.252  |
| eth         | This parameter specifies the behaviour of the Ethernet interface. Here following values can be set: <ul style="list-style-type: none"> <li>0 - Ethernet network interface is disabled completely. This means it is no longer possible to connect to E1702 via Telnet or via BeamConstruct. All SNTP-functionalities are disabled too. This option can be used to suppress illegal access to Ethernet, to save several seconds of startup-time and to save some power.</li> <li>1 - this mode enables the Ethernet interface and checks once at the beginning if some Ethernet hardware is connected to the controller card; when the "eth"-parameter is not specified at all, the resulting behaviour is the same</li> <li>2 - this enables Ethernet polling mode; instead of checking for an Ethernet device only once during boot, in this mode the interface is polled regularly until an electrical connection is detected. As long as the controller is polling, the Alive-LED blinks very slow and toggles once in about 20 seconds, when an Ethernet device was detected, the blink frequency changes to normal speed;<br/>PLEASE NOTE: when this mode is used, access via USB is delayed too, so "eth" should be set to "2" only when no communication via USB is intended.</li> </ul> | eth=0 - turn off Ethernet interface completely  |

| Parameter | Description  | Example   |
|-----------|--|---|
| pethd     | When Ethernet connection is used, it has to be established on power-up of the controller card as this connection is set-up and configured by the controller only once during boot. There may be situations where the other side of the Ethernet connection can not boot up as fast as E1702. In such cases this parameter can be used. It delays initialisation of Ethernet by the time given as parameter. The time is specified in unit "delayticks" where one "delaytick" is equal to about 0,5 seconds.<br>As long as the controller is halted during initialisation due to this parameter, this is signalled by the Stop-LED (please refer to 6.1.5 User LEDs for details). | pethd=20 - halt initialisation of the controller for about 10 seconds prior to initialisation of Ethernet interface |
| cswaf     | Sets a factor in unit bits per mm that is used with all commands that specify some distance or position (such as cspof). When this factor is set to a proper value, the given positions/distances can be specified in unit um instead of bits.<br>This parameter requires a firmware version 2 or newer.   | cswaf=671089 - set the conversion factor from bits to mm for a 100x100 mm working area                              |
| cxnc      | Configure the controller to accept G-Code data at the Ethernet-interface (via Telnet communication) or at the USB-serial interface instead of regular commands. When this option is set, the controller can be operated with a stream of G-Code data. Different to the command "cxnc" (as described in section "8.2 Stand-Alone Control Commands" below) this one is permanent, means the G-Code operation mode stays active also when the current CNC-program is marked to being complete by the code M2.<br>This parameter requires a firmware version 20 or newer.  | cxnc=1<br>enable the G-Code reception mode for the controller card  |

### 6.1.8.1 Firmware Update

As described above the firmware is located on microSD-Card and therefore can be updated easily:

1. remove the microSD-Card as described above
2. download a new firmware from <https://halaser.systems/download/Firmware/E1702> (the higher the number in the file name, the newer the firmware is)
3. copy the contents of this ZIP-file to microSD-Card (please take care about e1702.cfg in case it contains a changed configuration)
4. reinsert microSD-Card as described in previous section

## 6.1.9 Laser/Scanner Signals

### 6.1.9.1 XY2-100(E) Operation Mode

The white 26 pin connector provides several signals to be used to control up to two galvos of a scanhead and a laser source. It can be connected to an XY2-100 or XY2-100-E compatible scanner system via an adapter cable which splits XY2-100 and laser/input control signals. The connector provides following signals:

| Upper Row Of Pins | Signal    | Voltage              | Remarks                                 | Lower Row Of Pins | Signal    | Voltage              | Remarks                                 |
|-------------------|-----------|----------------------|---|-------------------|-----------|----------------------|---|
| 1                 | CLK-      |                      | XY2-100- / XY2-100-E-compatible signals | 2                 | CLK+      |                      | XY2-100- / XY2-100-E-compatible signals |
| 3                 | SYNC-     |                      |   | 4                 | SYNC+     |                      |   |
| 5                 | X-        |                      |   | 6                 | X+        |                      |   |
| 7                 | Y-        |                      |   | 8                 | Y+        |                      |   |
| 9                 | LP8_0     | CMOS, 0/5V, max 8 mA | Laser power control signals             | 10                | GND       | GND                  | Input control signals                   |
| 11                | LP8_1     |                      |   | 12                | ExtStart  | CMOS, 0/5V           |   |
| 13                | LP8_2     |                      |   | 14                | ExtStop   |                      |   |
| 15                | LP8_3     |                      |   | 16                | Pilot     | CMOS, 0/5V, max 8 mA | Laser control signals                   |
| 17                | LP8_4     |                      |   | 18                | MO        |                      |   |
| 19                | LP8_5     |                      |   | 20                | LaserGate |                      |   |
| 21                | LP8_6     |                      |   | 22                | LaserA    |                      |   |
| 23                | LP8_7     |                      |   | 24                | 5V        | 5V                   |   |
| 25                | LP8 Latch |                      |   | 26                | LaserB    | CMOS, 0/5V, max 8 mA |   |

Laser Gate provides laser modulation signal, turns on the laser during marks and off during jumps.

LaserA usage depends on software configuration and control, it is able to output a pulse-width modulated frequency (e.g. for controlling CO<sub>2</sub> lasers), CW/continuously running frequency (e.g. for fiber lasers) or Q-Switch signal (e.g. for YAG lasers) in range 25 Hz..20 MHz.

LaserB can be used for emitting a FPK pulse (e.g. for YAG lasers).

ExtStart expects a CMOS-level input signal in respect to GND and can be used as external trigger signal to start operations when a HIGH-signal is detected at input pin.

ExtStop expects a CMOS-level input signal in respect to GND and can be used as external stop-signal in order to stop a running marking operation by using a HIGH-signal at input pin.

LP8\_0...LP8\_7 provide parallel 8 bit output signal (e.g. for power control with MOPA lasers).

LP8 Latch pin signals valid output at LP8\_0..LP8\_7 by submitting a latch pulse of software-controlled length.

MO can be used to enable main oscillator (e.g. for MOPA lasers).

### **6.1.9.2 XY3-100 Operation Mode**

The E1702S can operate in XY3-100 mode too. The controller can be connected to an XY3-100 compatible scanner system via an adapter cable which splits XY3-100 and laser/input control signals. The white connector of the E1702S provides following signals:

| Upper Row Of Pins | Signal    | Voltage              | Remarks                     | Lower Row Of Pins    | Signal | Voltage   | Remarks               |  |
|-------------------|-----------|----------------------|-----------------------------|----------------------|--------|-----------|-----------------------|--|
| 1                 | SYNC-     |                      | XY3-100 signals             | 2                    | SYNC+  |           | XY3-100 signals       |  |
| 3                 | CLK-      |                      |                             | 4                    | CLK+   |           |                       |  |
| 5                 | X-        |                      |                             | 6                    | X+     |           |                       |  |
| 7                 | Y-        |                      |                             | 8                    | Y+     |           |                       |  |
| 9                 | LP8_0     | CMOS, 0/5V, max 8 mA | Laser power control signals | 10                   | GND    | GND       |                       |  |
| 11                | LP8_1     |                      |                             | CMOS, 0/5V           | 12     | ExtStart  | Input control signals |  |
| 13                | LP8_2     |                      |                             |                      | 14     | ExtStop   |                       |  |
| 15                | LP8_3     |                      |                             | CMOS, 0/5V, max 8 mA | 16     | Pilot     | Laser control signals |  |
| 17                | LP8_4     |                      |                             |                      | 18     | MO        |                       |  |
| 19                | LP8_5     |                      |                             |                      | 20     | LaserGate |                       |  |
| 21                | LP8_6     |                      |                             |                      | 22     | LaserA    |                       |  |
| 23                | LP8_7     |                      |                             |                      | 24     | 5V        | 5V                    |  |
| 25                | LP8 Latch |                      |                             |                      | 26     | LaserB    | CMOS, 0/5V, max 8 mA  |  |

Except for the XY3-100 signals, in this mode, pinout and signals are the same as described in section “6.1.9.1 XY2-100(E) Operation Mode” above.

### 6.1.9.3 NX-02 Operation Mode

Beside the two operation modes described above, the E1702S can operate in NX-02 operation mode too. Here the complete scanner control signals are transmitted via two single wires, thus this mode is recommended to be used in environments where not enough space is available for the thicker XY2/XY3 cables. In NX-02-mode the white connector of the E1702S provides following signals:

| Upper Row Of Pins | Signal    | Voltage              | Remarks                     | Lower Row Of Pins    | Signal | Voltage   | Remarks               |  |
|-------------------|-----------|----------------------|-----------------------------|----------------------|--------|-----------|-----------------------|--|
| 1                 | DATA+     |                      | NX-02 output signal         | 2                    | DATA-  |           | NX-02 output signal   |  |
| 3                 |           |                      | Do not use                  | 4                    |        |           | Do not use            |  |
| 5                 |           |                      | Do not use                  | 6                    |        |           | Do not use            |  |
| 7                 |           |                      | Do not use                  | 8                    |        |           | Do not use            |  |
| 9                 | LP8_0     | CMOS, 0/5V, max 8 mA | Laser power control signals | 10                   | GND    | GND       |                       |  |
| 11                | LP8_1     |                      |                             | CMOS, 0/5V           | 12     | ExtStart  | Input control signals |  |
| 13                | LP8_2     |                      |                             |                      | 14     | ExtStop   |                       |  |
| 15                | LP8_3     |                      |                             | CMOS, 0/5V, max 8 mA | 16     | Pilot     | Laser control signals |  |
| 17                | LP8_4     |                      |                             |                      | 18     | MO        |                       |  |
| 19                | LP8_5     |                      |                             |                      | 20     | LaserGate |                       |  |
| 21                | LP8_6     |                      |                             |                      | 22     | LaserA    |                       |  |
| 23                | LP8_7     |                      |                             |                      | 24     | 5V        | 5V                    |  |
| 25                | LP8 Latch |                      |                             |                      | 26     | LaserB    | CMOS, 0/5V, max 8 mA  |  |

Except for the NX-02 data output wires, in this mode, pinout and signals are the same as described in section “6.1.9.1 XY2-100(E) Operation Mode” above.

### 6.1.9.4 XY2-100 Connection Cable

E1702S scanner controller board can operate an XY2-100-compatible scanner system directly. Here an adapter-cable is required that splits XY2-100 signals and additional laser/input control signals. Using such a cable, the white 26 pin connector described above, should be converted to a female, XY2-100-compatible, 25 pin SUB-D connector (to connect with scanhead) and an other connector (which provides laser signals and start/stop inputs).

Pinout of a D-SUB25 XY2-100 connector should conform to the standard. GND is not required for signal transmission and therefore is optional:



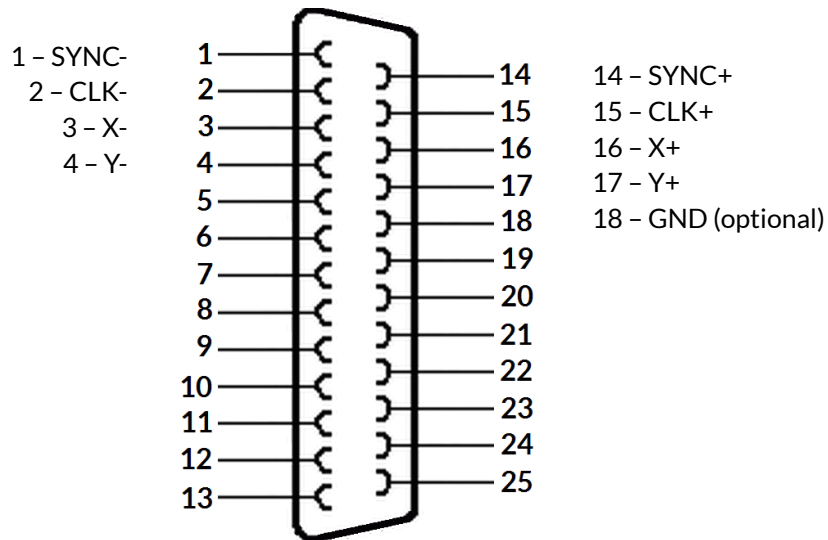

### 6.1.10 Extension Connectors

The two extension connectors on each side of the board can be used to place extension boards with additional peripheral interfaces. The extension connectors are designed to place/remove boards from time to time but they are not intended for constant hardware changes. So changing extension boards repeatedly and often e.g. as permanent part of a production process is not recommended.

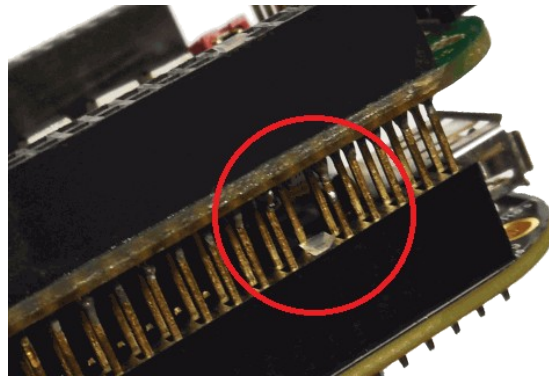

Key pin closed on lower connector and missing in upper board to ensure correct orientation

- !** PLEASE NOTE: when placing a new extension board
1. check correct orientation and position of the key pin which is closed in connector
  2. place the pins of the extension boards onto the extension connectors exactly
  3. move down the extension board by pressing on its extension connectors gently; **DO NOT PRESS THE BOARD ITSELF BUT ONLY THE CONNECTORS!**

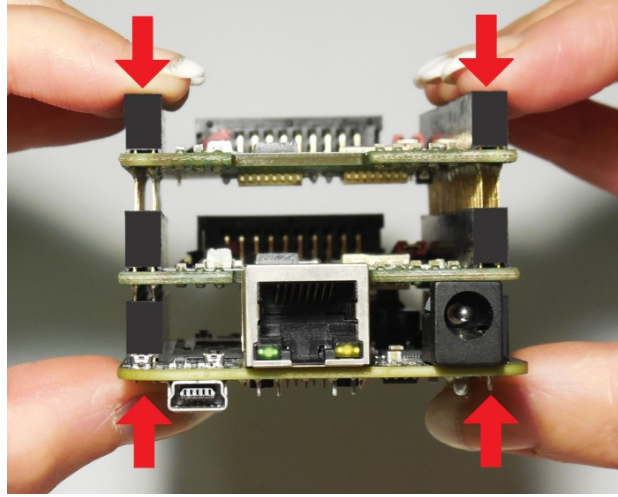

 PLEASE NOTE: When removing an extension board DO NOT pull on the extension connectors but hold both boards on their long side directly at the PCBs edges:

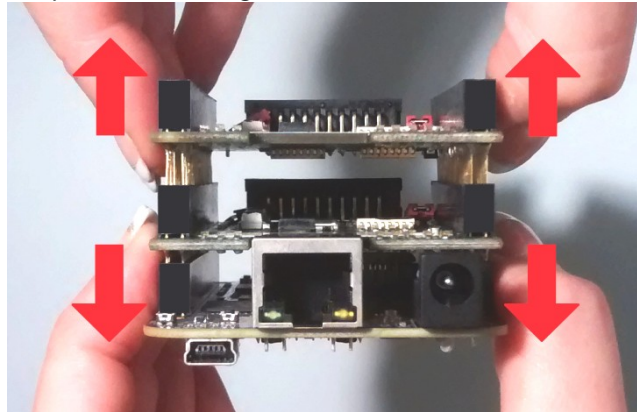

Due to the large number of pins, it is easy to plug in an extension but more difficult to pull it out. So when removing an extension board, it is recommended to be very slow and to carefully pull each side up just a little bit to avoid bending of the pins as they exit.

### 6.1.11 Stand-Alone Operation

E1702 scanner controller cards can be operated in stand-alone mode. In this mode all marking data are stored on SD-card and the board can operate without direct control of a host-PC that sends the data to be marked. Such stand-alone marking data can be created e.g. in BeamConstruct marking software.

The names of these stand-alone files are allowed to have a maximum length of 30 characters (including the dot and the file extension). There are two possibilities to have stand-alone data on the SD-card:

- BEAMP project files like they are used within BeamConstruct (requires firmware version 3 or higher)
- EPR files which can be generated in BeamConstruct out of a BEAMP project file

These two variants differ in its possibilities:

- EPR files are optimised for the target system within BeamConstruct, so they are smaller, and load faster in stand-alone mode for the price of limited features and functions
- BEAMP files support more functions and features and are less limited, but for the price of not being optimised, so loading of these files from SD-card is slower compared to EPR files

#### 6.1.11.1 Stand-Alone Operation with EPR files

The base-stand-alone file comes with a file-extension .EPR. In case the stand-alone file contains dynamic data, a second file with the same filename but the extension .DAT is created (for details about dynamic stand-alone data please refer to section "6.1.11.1 Create Stand-Alone EPR Data with BeamConstruct"). When a stand-alone-mode of type "ioselect" is used, the filename has to follow some specific rules too, here it typically has to

be a number which corresponds to the selection done at the digital inputs (for details about the different stand-alone modes and their behaviour please refer to section "6.1.11.3 Stand-Alone Configuration Parameters").

### 6.1.11.1.1 Create Stand-Alone EPR Data with BeamConstruct

To use BeamConstruct for generation of stand-alone EPR data for E1702 scanner controllers, the card has to be fully configured (including all scanner, laser and pen-parameters). Next the marking data to be stored on SD-card have to be created. To generate stand-alone data, menu "Processing", sub-menu "Write Marking Data to File" or "Send Named Marking Data" has to be selected.

First one gives the possibility to write the data to microSD card when E1702 is switched off and the microSD card is plugged into host PC. Here it is recommended to use file extension ".EPR" for the file generated by BeamConstruct. Next it is also recommended to always let BeamConstruct write to microSD card directly because sometimes more than only one file is created. Direct write operation to BeamConstruct ensures all files are available on microSD and no data can be forgotten to be copied.

The second variant allows to download the stand-alone data to the controller while it is connected and running. Precondition for sending data to a running controller are:

- no mark operation is in progress (controller is idle)
- no stand-alone project is loaded (please refer to description of ioselect-mode and stand-alone control commands below).
- a valid name is given in style 0:/filename.epr

This operation creates the .EPR-file and all additional files on microSD card of the running controller automatically.

 PLEASE NOTE: such an .EPR-stand-alone file can NOT be converted back to vector data that could be edited in BeamConstruct! Creating these files is a one-way-conversion of your projects. Thus it is recommended to save these projects twice – once as normal .BEAMP-File which can be loaded and modified later and once as .EPR-file which has to be used on SD-card. This also means such .EPR-files are protected so that it is possible to give away designs to some end-users which shall not be able to modify them.

E1702 controller supports all static data in stand-alone mode (like all kinds of static geometries, output signals, waiting for input commands, waiting for trigger, all laser- and scanner parameters). But it does not store the vector data using a possibly configured correction table! To get a valid correction for stand-alone operations, the related correction file has to be saved on microSD card and needs to be activated using parameter "corrtable0" in e1702.cfg configuration file (please refer to description above).

Next E1702 scanner card supports dynamic content (means content which can be changed later when running in stand-alone mode) when following conditions are met:

- a text element uses one of the laser vector font families "Roman", "Script" or "Times" and it makes use of an input element or
  - a text element makes use of a TrueType font and it makes use of an input element; here any available TrueType font can be used and several hatch-patterns can be applied
- for both types of text some limitations apply (only left to right orientation, no scaling/rotation/slant/mirroring is applied to the font and only the characters ' ', !, ", #, \$, %, &, \, (, ), \*, +, ,, -, ., /, 0, 1, 2, 3, 4, 5, 6, 7, 8, 9, :, ;, <, =, >, ?, @, A, B, C, D, E, F, G, H, I, J, K, L, M, N, O, P, Q, R, S, T, U, V, W, X, Y, Z, [, \, ], ^, \_ ` a, b, c, d, e, f, g, h, i, j, k, l, m, n, o, p, q, r, s, t, u, v, w, x, y, z, {, |, } and ~ can be used, BeamConstruct version 4.8 or newer is required); or
- a barcode element uses type "DataMatrix" with option "MergeCells" disabled and it makes use of an input element
  - any kind of hatch and combined hatches can be applied to a barcode element (but not to a text element)
  - marking output is neither XY-flipped nor mirrored nor rotated or slanted
  - when an input element of type "Serial Number" is used, serial number counting is done according to the settings of the related element
  - when an input element of type "CSV File Data" is used, elements out of a CSV-table can be read and used for the dynamic element:

the CSV-file itself needs to be placed on the SD-card and has to use the same name like the EPR file but with extension CSV (so when the stand-alone file is named "data.epr", the CSV-file needs to be named "data.csv"), resulting from that one EPR file can handle exactly one CSV file;

supported parameters of the CSV input element are the column separator, the data column to read the data from and the "Endless loop" option (for details please refer to the manual of BeamConstruct)

- when any input element is used, the contents of the text/barcode can be changed via command "cstxt", in this case the automatic updating of the input element has no effect

When these conditions are met, a text or barcode can be modified during stand-alone operation either via stand-alone control commands as described below or via a Serial Number input element that is applied to it in BeamConstruct. Here all serial number, time, date and formatting functions of this input element are supported. To get a valid time in stand-alone mode, it needs to be set after boot-up via stand-alone control commands (as described below) or a SNTP time server has to be configured to retrieve current time from an external source (please refer to description e1702.cfg parameters above).

### ***6.1.11.2 Stand-Alone Operation with BEAMP files***

This feature requires a firmware version 3 or newer:

When BEAMP-project files have to be used, no special conversion is necessary. Here as only precondition the BEAMP-project file itself needs to be configured for usage with the E1702S controller card. Once this was done and the project works properly out of BeamConstruct, it can be saved and the BEAMP file can be copied to the SD-card of the controller card.

As BeamConstruct provides a GUI and user interaction which is not available in stand-alone mode, some limitations apply to BEAMP project files too. So all functions, which are related to hardware or devices which are not the E1702S controller, are ignored. Same is true for all functions that cause something being displayed to the user. Furthermore no Unicode data/characters are supported, so one should strictly use only plain ASCII-characters everywhere within a BEAMP project.

Following features are supported when a BEAMP project file is executed in stand alone mode:

- full support of all primary elements that contain geometries including commands for manipulating these elements position, rotation, size,...
- support of control primary elements as long as the related hardware is accessible (such as Delay, External Trigger, Custom Input, Custom Output – other elements are available on request)
- support of Text elements including the possibility to dynamically change the contents of the text element via an input element or a command without further preconditions (currently only Laser Vector fonts are supported)
- support of Barcode elements including the possibility to dynamically change the contents of the text element via an input element or a command without further preconditions (currently DataMatrix and QR barcodes are supported, additional barcode types are available on request)
- Support of input elements to automatically change the contents of a superior element (such as Serial/Date/Time, other input elements are available on request)
- Support of post-processing elements to update the geometries of a superior element when it was modified (such as Curve Distortion, other post-processing elements are available on request)
- Support of the Hatcher additional element to update the hatch of a superior element when it was changed (support of all line-style hatch types, no beam-compensation and no inner/outer lines are supported as well as the hatch tiling)
- support of all custom dot styles which applies to elements that are updated via input elements or external commands

### ***6.1.11.3 Stand-Alone Configuration Parameters***

Within e1702.cfg configuration file of E1702 scanner controller one of the following stand-alone operation modes can be selected via the configuration parameter "standalone":

```
standalone=off
```

Stand-alone mode is fully disabled, the card acts as normal, host-PC-controlled device and all .EPR- and .BEAMP-files on the SD-card are ignored. Digital outputs are not toggled since no stand-alone operational states have to be signalised here (please refer next section).

```
standalone=auto
```

Stand-alone mode is enabled, a file specified by and additional parameter "autofile" is loaded and prepared for marking. Marking of this file is started only when an external trigger signal is detected. The file itself has to be specified via additional configuration parameter that gives the filename of the stand-alone file to be loaded. As an example a parameter: "autofile=0:/myfile.epr" would try to load the file "myfile.epr" from SD-card and prepare it for marking. In this mode the digital outputs are toggled as described in next section.

```
standalone=loop
```

This is the same like mode "auto" described above, but using "loop" the E1702 controller does NOT wait for an external trigger signal! So when no trigger points are set in stand-alone datafile itself, in this mode marking would be done in an infinite loop, repeating the given "autofile" again and again.

```
standalone=haltedloop
```

This is the same like mode "loop" described above, but marking does not start immediately. By default the controller is in state "halt" until the ExtStart input is set to HIGH level. Marking continues only as long this input stays at HIGH. When it goes back to LOW, marking is continued until the laser is turned off the next time (defined by the geometry which is currently loaded) and it is halted again. Next time ExtStart goes to HIGH, marking continues at the position where it was halted before.

Please note: for this mode it is recommended to have marking data with vectors that are interrupted by jumps from time to time. When ExtStart goes to LOW, marking continues until the next jump is found. This means, when the controller processes a complex, long-lasting vector, marking will continue for the whole time this vector needs although ExtStart is already wt LOW. So the laser is never interrupted and turned off within a mark operation.

In this mode the timeout-parameter "haltedlooptimeout" is used.

```
standalone=iohaltedloop
```

This mode is a combination out of "haltedloop" described above and "ioselect" described below (please refer there for usage details). In this mode a project can be selected via digital inputs of Digi I/O Extension Board but it is started immediately and marked in an endless loop as long as ExtStart input is HIGH (so the level at ExtStart is checked, not the rising edge of an applied signal). When a different project is selected by applying a different input pattern at DIn digital inputs, the current project is cancelled and the new one is started in a loop again.

In this mode the timeout-parameter "haltedlooptimeout" is used.

```
standalone=ioselect
```

This mode requires Digi I/O Extension Board (please refer below). Here it is possible to select one of 256 stand-alone marking jobs via the digital inputs. The number that results out of the input pattern of the Digi I/O input lines specifies the filename of the marking job that has to be loaded from SD card:

| Selected input(s)                                  | Stand-alone file loaded from SD-card |
|--|--------------------------------------|
| All inputs set to LOW (not recommended to be used) | 0.epr / 0.beamp                      |
| DIn0 set to HIGH                                   | 1.epr / 1.beamp                      |
| DIn1 set to HIGH                                   | 2.epr / 2.beamp                      |
| DIn0 and DIn1 set to HIGH                          | 3.epr / 3.beamp                      |
| DIn2 set to HIGH                                   | 4.epr / 4.beamp                      |
| DIn0 and DIn2 set to HIGH                          | 5.epr / 5.beamp                      |
| DIn1 and DIn2 set to HIGH                          | 6.epr / 6.beamp                      |

|                                 |                     |
|---------------------------------|---------------------|
| DIn0, DIn1 and DIn2 set to HIGH | 7.epr / 7.beamp     |
| DIn3 set to HIGH                | 8.epr / 8.beamp     |
| ...                             | ...                 |
| DIn4 set to HIGH                | 16.epr / 16.beamp   |
| ...                             | ...                 |
| DIn5 set to HIGH                | 32.epr / 32.beamp   |
| ...                             | ...                 |
| DIn6 set to HIGH                | 64.epr / 64.beamp   |
| ...                             | ...                 |
| DIn7 set to HIGH                | 128.epr / 128.beamp |
| ...                             | ...                 |
| All inputs set to high          | 255.epr / 255.beamp |

 PLEASE NOTE: 0.epr or 0.beamp (no inputs set to HIGH) can be used but it is not recommended to do that. This value should be reserved for "no job active" to set the card into an inactive mode also in stand-alone operational mode. This may be necessary e.g. when new project data are downloaded to the controller without removing the SD-card.

Marking of a IO-selected job is started by external trigger signal (ExtStart input). When the input pattern at DIn0..DIn7 changes during marking, the currently running operation is continued and the other stand-alone job is loaded after marking operation has finished. In this mode the digital outputs are toggled as described in next section.

In stand-alone mode "ioselect" and "idxselect" .EPR-files or .BEAMP-file are loaded from microSD card as soon as a new input pattern is detected at digital inputs or as soon as a new index is loaded by command "clepr". Depending on the size of the .EPR file/depending on the size and complexity of the .BEAMP-file and the speed of the microSD card, this may take a time that is too long for high-speed applications. Thus it is possible to operate such projects from controller's RAM completely: in e1702.cfg the numbers of the files to be loaded have to be specified with parameter "iobuff", it can be used up to 20 times and expects the number of the file (so a line "iobuff=3" would be responsible for preloading file "0:/3.epr" or "0:/3.beamp"), file "0.epr"/"0.beamp" can not be loaded by this command.

Now these files are loaded into RAM and switching from one to an other is done much faster since toggling between them is done controller-internal and no more disk-operations are necessary for that. For .BEAMP files, the load time from SD-card is eliminated by this function, but the preprocessing time after loading will still be there.

 PLEASE NOTE: when too much too large .EPR/BEAMP files are selected for preloading, this may exceed the available memory on card. This is signalled by the Error LED turned on and an appropriate message is stored in log buffer. In such a case a proper operation is no longer guaranteed.

```
standalone=idxselect
```

This mode works exactly like the mode "ioselect" (described above), but it does not need the Digi I/O Extension board. Instead of that, loading of a file can be done via an index number and the command `clepr`. There the number of the file to be loaded has to be given. For a full description of all functions and features of mode "idxselect", please refer the "ioselect" description above.

```
iolatch=1
```

This option can be enabled for one of the digital-input-controlled stand-alone modes "ioselect", "idxselect" and "iohaltedloop". When this option is set to 0 or when it does not exist in e1702.cfg, the digital input bitpattern at DIn0..DIn7 is used as new input value as soon as it is detected. When it is enabled, DIn7 is used as latch-bit. Then the digital input bitpattern at DIn0..DIn6 is used only when DIn7 is set to HIGH. So a proper method of selecting a digital input bitpattern with latch enabled would be:

- ensure DIn7 is at LOW
- apply the desired bitpattern at DIn0..DIn6
- wait for the maximum time the input bits may need to settle (depends on the external hardware and its capabilities)
- set DIn7 to HIGH
- wait until DOut0 goes to LOW
- wait until DOut0 goes back to HIGH (when a valid bitpattern was applied that corresponds to an existing EPR file) or until loading timeout has elapsed (when a bitpattern has been applied where no EPR file exists for
- set DIn7 to LOW

So as long as DIn7 is at low, state-changes at DIn0..DIn6 are ignored and the last detected bitpattern is used. In this mode only 127 different input bitpatterns are possible as DIn7 is used as latch bit.

#### ***6.1.11.4 Stand-Alone Control***

The current stand-alone operational state is signalled via digital outputs (requires Digi I/O Extension Board):

**DOut0** – ready for marking – this output goes to HIGH as soon as a stand-alone job could be found on disk, was loaded successfully and is ready for marking. So external start signal should not be given until this output is HIGH. When a new stand-alone file is selected (e.g. via digital inputs in "ioselect"-mode) this output goes to LOW. It is switched back to HIGH only when the new file could be loaded successfully too.

This signal can be mapped to a different hardware output using configuration parameter `tunereadyout` and the related tune-flag.

**DOut1** – marking active – as long as this output is HIGH, a marking operation is in progress. When a different stand-alone file is selected (e.g. via digital inputs) as long as this output is HIGH, marking is continued and the new file is NOT loaded. Once the current marking operation is completed, the output goes to LOW. After that the board continues with current marking data (when no new ones have been selected), or it tries to load new ones (when a new file was selected).

This signal can be mapped to a different hardware output using configuration parameter `tunemarkout` and the related tune-flag.

## 6.2 E1702 Digi I/O Extension Board

The E1702 Digi I/O Extension Board can be used with the E1702S baseboards and provides following features:

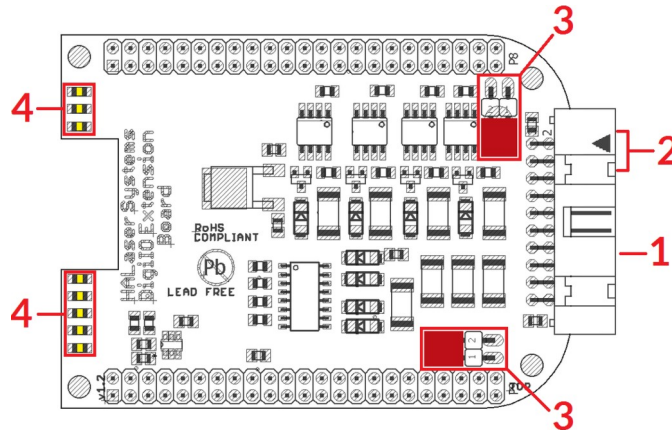

1. Digi I/O – electrically insulated digital in- and outputs
2. optional inputs for 90 degree phase shifted encoders to be used with marking on-the-fly operations
3. Opto-Configuration – choose operation mode for Digi I/Os
4. Input state LEDs – displaying of HIGH/LOW state of used inputs

In case more extension boards are used on E1702S, Digi I/O extension always has to be placed on top.

### 6.2.1 Digi I/O

The 20 pin connector provides 8 lines for input and 8 lines for output of digital signals that can work on CMOS level (non-insulated mode) or via opto-couplers (electrically insulated mode with external power supply) optionally. The operation mode depends on jumper settings described below. The connector is used as follows:

| Upper Row Of Pins | Signal           | Voltage                          | Remarks   | Lower Row Of Pins | Signal             | Voltage                          | Remarks  |
|-------------------|------------------|----------------------------------|---|-------------------|--------------------|----------------------------------|--|
| 1                 | V <sub>ext</sub> | 5..24V                           | Input voltage to be used in opto-insulated mode only                | 2                 | GND <sub>ext</sub> | GND                              | External ground                                |
| 3                 | DOut0            | CMOS, 0/5V or 0/V <sub>ext</sub> | Default level: LOW <sup>1)</sup>                                    | 4                 | DIn0               | CMOS, 0/5V or 0/V <sub>ext</sub> | Encoder-input A1 for marking on-the-fly        |
| 5                 | DOut1            | CMOS, 0/5V or 0/V <sub>ext</sub> | Default level: LOW <sup>1)</sup>                                    | 6                 | DIn1               | CMOS, 0/5V or 0/V <sub>ext</sub> | Encoder-input B1 for marking on-the-fly        |
| 7                 | DOut2            | CMOS, 0/5V or 0/V <sub>ext</sub> | Default level: LOW <sup>1)</sup>                                    | 8                 | DIn2               | CMOS, 0/5V or 0/V <sub>ext</sub> | Second encoder-input A2 for marking on-the-fly |
| 9                 | DOut3            | CMOS, 0/5V or 0/V <sub>ext</sub> | Default level: LOW <sup>1)</sup>                                    | 10                | DIn3               | CMOS, 0/5V or 0/V <sub>ext</sub> | Second encoder-input B2 for marking on-the-fly |
| 11                | DOut4            | CMOS, 0/5V or 0/V <sub>ext</sub> | Default level: HIGH <sup>1)</sup>                                   | 12                | DIn4               | CMOS, 0/5V or 0/V <sub>ext</sub> |  |
| 13                | DOut5            | CMOS, 0/5V or 0/V <sub>ext</sub> | Default level: HIGH <sup>1)</sup>                                   | 14                | DIn5               | CMOS, 0/5V or 0/V <sub>ext</sub> |  |
| 15                | DOut6            | CMOS, 0/5V or 0/V <sub>ext</sub> | Default level: HIGH <sup>1)</sup>                                   | 16                | DIn6               | CMOS, 0/5V or 0/V <sub>ext</sub> |  |
| 17                | DOut7            | CMOS, 0/5V or 0/V <sub>ext</sub> | Default level: HIGH <sup>1)</sup>                                   | 18                | DIn7               | CMOS, 0/5V or 0/V <sub>ext</sub> |  |
| 19                | V                | 5V                               | Board voltage, to be used only when not operating in insulated mode | 20                | GND                | GND                              | Board-internal ground                          |

<sup>1)</sup> Please note the wiring scheme and the resulting, inverted logic below: a level of LOW means, the output is pulled to GND and a load that is connected from V to this pin is turned on. An level of HIGH means, the output is pulled to V and a properly wired load if turned off.

V<sub>ext</sub> and GND<sub>ext</sub> depend on opto-configuration as described below. In opto-insulated mode (opto-configuration jumpers not set) external power supply has to be connected to these inputs. Then DIn0..DIn7 and DOut0..DOut7 work in respect to this external power.

 **WARNING:** When no opto-insulated mode is selected (opto-configuration jumpers are set), do NOT FEED ANY POWER into V<sub>ext</sub>, this would cause damage to the E1702 board! In this case V<sub>ext</sub> is equal to V (5V) of the board and GND<sub>ext</sub> is connected to boards ground GND.

Maximum current for every output is 15 mA when internally powered (non-insulated mode), here it is recommended to use an external power supply.

Maximum current for outputs DOut0..DOut3 is 50 mA when externally powered (V<sub>ext</sub> in insulated mode). Signal output lines DOut0..DOut7 operate in open collector mode and have to be wired as follows:

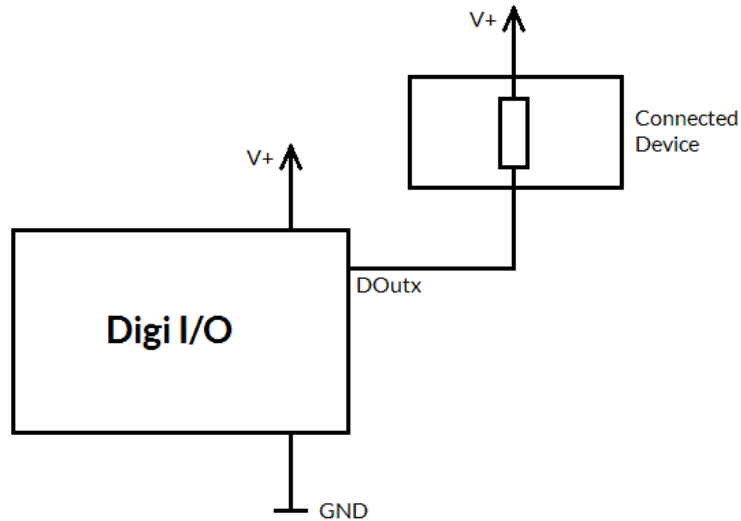

Here “DOutx” symbolises one of the digital outputs DOut0..DOut7. V+ is either V (5V internal, non-insulated mode) or  $V_{ext}$  (up to 24V external, insulated mode). GND is either GND (non-insulated mode) or  $GND_{ext}$  (insulated mode). The internal resistor of the connected device is not allowed to have less than 490 Ohms in order to not exceed the given current limits. DOut0..DOut3 provide LOW signal level by default, DOut4..DOut7 provide HIGH level by default. These levels are valid immediately on power-up of the card.

### 6.2.1.1 Marking On-The-Fly Signals

Digital inputs 0 and 1 can be used as position encoder signal inputs for marking on-the-fly applications. Here 90 degree phase-shifted input pulses are expected signalling motion direction and position change:

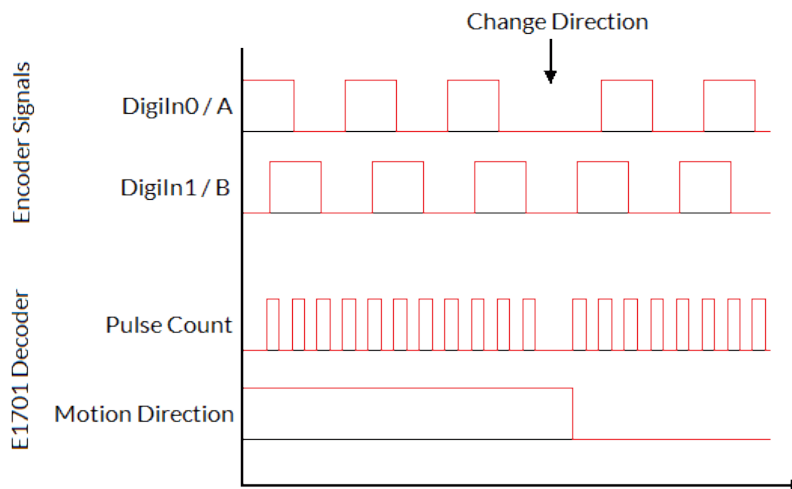

When these pulses are generated from a motion stage that moves the working piece, the resulting position information is used in marking on-the-fly mode to correct the marking positions accordingly. Resulting from that, marking will follow motion as far as available scanhead range and working area allows it.

The pulses generated out of the encoder signals have to be multiplied with a factor reflecting the resolution of the used encoder. To set up and adjust a marking on-the-fly-system properly, following steps have to be performed:

1. Connect encoder signals A1 and B1 to DigIn0 and DigIn1 and configure E1702 controller for encoder usage (either from within BeamConstruct or via programming interface as described below)
2. Mark a square without any encoder signals feed into the controller
3. When the square does not have exact size and/or is distorted, modify correction table and/or gain settings
4. Mark the same square with a slow motion (using encoder pulses)

5. When the square is damaged (means open on one side or compressed) the on-the-fly-factor has to be changed (set to a smaller or higher value)
6. Mark the same square with a fast motion (using encoder pulses)
7. When the square is damaged (means open on one side or compressed) the on-the-fly-factor has to be changed (set to a smaller or higher value)

The on-the-fly-factor controls the strength of compensation and is the relation between speed of external device/encoder pulses and card-internal compensation calculation. When this factor is wrong, the marking results are distorted. For a square (as recommended to be used in calibration steps above) following results are imaginable:

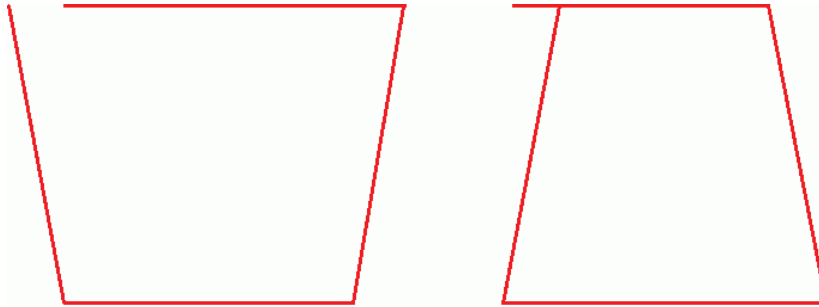

The left drawing shows an over-compensated system, here the internal compensation is too strong, the factor is too big. The right drawing shows an under-compensated set-up, here the factor is too small causing a too weak compensation. Only when marking result is really a square, the on-the-fly-factor is correct.

When “tune”-flag 2 is set, a second encoder can be used for 2D marking on-the-fly applications. In this mode digital inputs 0 and 1 (encoder inputs A1 and B1) correspond to X axis and on-the-fly factor for X direction. Additionally digital inputs 2 and 3 (encoder inputs A2 and B2) correspond to Y axis and on-the-fly factor for Y direction. Operation principle is the same as for 1D on-the-fly described above: the incremental values received from the encoders for X and Y are added to the current X and Y coordinates to be marked. Procedure for adjusting the encoder factor is also the same, here it is recommended to perform this operation for X and Y movements separately and finally try both motion directions together.

### 6.2.2 Opto-Configuration

Using these jumpers the operation mode for digital I/Os 0..7 can be chosen. When they are set, the opto-couplers are powered internally. In this mode it is not working in opto-insulated mode and I/Os are using CMOS level signals.

When they are not set, external power and ground has to be provided at 20 pin connector (as described above) and these digital I/Os are working in electrically insulated, opto-coupled mode.

### 6.2.3 Input State LEDs

These 8 yellow LEDs show the state of corresponding 8 digital inputs. As long as a HIGH signal is detected on an input, the related LED is turned on.

## 6.3 E1702 Secondary Head Extension Board



The E1702 Secondary Head Extension Board can be used up to three times with the same E1702S Baseboard to have a scanner controller system with a total of up to four heads connected. These additional scanheads work fully parallel to the primary scanhead of E1702S baseboard.

It provides following features:

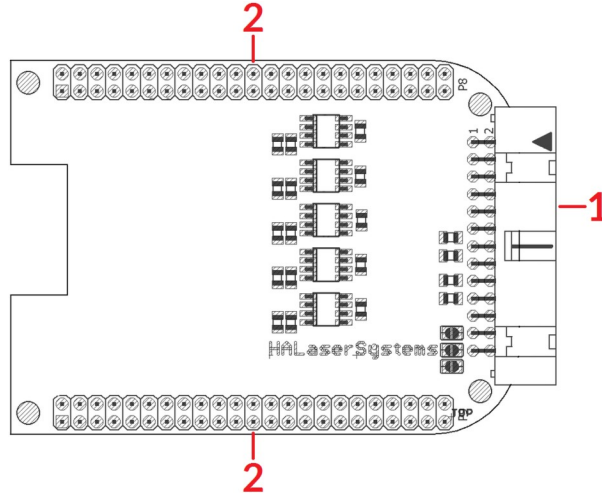

1. XY2-100 or XY3-100 signals to scanhead
2. Extension connectors – more extension boards can be placed here in order to add some more functionality and hardware interfaces to the board, please refer to related section in description of baseboard above

### 6.3.1 Scanner Signals

The white 26 pin connector provides XY2-100-compliant signals to be used to control up to two galvos of a scanhead. It can be connected to an XY2-100 compatible scanner system directly and without further modifications when a 1:1 connection to a D-SUB25 connector is used.

The connector provides following signals:

| Upper Row Of Pins | Signal | Voltage | Remarks                                 | Lower Row Of Pins | Signal | Voltage | Remarks                                 |
|-------------------|--------|---------|---|-------------------|--------|---------|---|
| 1                 | CLK-   |         | XY2-100- / XY2-100-E-compatible signals | 2                 | CLK+   |         | XY2-100- / XY2-100-E-compatible signals |
| 3                 | SYNC-  |         |   | 4                 | SYNC+  |         |   |
| 5                 | X-     |         |   | 6                 | X+     |         |   |
| 7                 | Y-     |         |   | 8                 | Y+     |         |   |
| 9                 |        |         | do not connect!                         | 10                |        |         | do not connect!                         |
| 11                |        |         |   | 12                |        |         |   |
| 13                |        |         |   | 14                |        |         |   |
| 15                |        |         |   | 16                |        |         |   |
| 17                |        |         |   | 18                |        |         |   |
| 19                |        |         | 20                                      | GND               | GND    |         |   |
| 21                | GND    | GND     |   | 22                | GND    | GND     |   |
| 23                |        |         | do not connect!                         | 24                |        |         | do not connect!                         |
| 25                |        |         |   | 26                |        |         |   |

Comparing to E1702S Baseboard this connector does not provide any laser signals (like LaserGate, LaserA or LaserB). Since this scanner output works completely parallel to the one from E1702S Baseboard it has to be used together with the same laser using beam splitters.

When operated in XY3-100 mode, the related signals are provided at the white 26 pin connector. It can be connected to an XY3-100 compatible scanner system directly and without further modifications when a 1:1 connection to a D-SUB25 connector is used.

The connector provides following signals:

| Upper Row Of Pins | Signal | Voltage | Remarks         | Lower Row Of Pins | Signal | Voltage | Remarks         |
|-------------------|--------|---------|-----------------|-------------------|--------|---------|-----------------|
| 1                 | SYNC-  |         | XY3-100-signals | 2                 | SYNC+  |         | XY3-100-signals |
| 3                 | CLK-   |         |                 | 4                 | CLK+   |         |                 |
| 5                 | X-     |         |                 | 6                 | X+     |         |                 |
| 7                 | Y-     |         |                 | 8                 | Y+     |         |                 |
| 9                 |        |         | do not connect! | 10                |        |         | do not connect! |
| 11                |        |         |                 | 12                |        |         |                 |
| 13                |        |         |                 | 14                |        |         |                 |
| 15                |        |         |                 | 16                |        |         |                 |
| 17                |        |         |                 | 18                |        |         |                 |
| 19                |        |         | 20              | GND               | GND    |         |                 |
| 21                | GND    | GND     |                 | 22                | GND    | GND     |                 |
| 23                |        |         | do not connect! | 24                |        |         | do not connect! |
| 25                |        |         |                 | 26                |        |         |                 |

Comparing to E1702S Baseboard this connector does not provide any laser signals (like LaserGate, LaserA or LaserB). Since this scanner output works completely parallel to the one from E1702S Baseboard it has to be used together with the same laser using beam splitters.

When working in NX-02 mode, the related signals are provided at the white 26 pin connector.

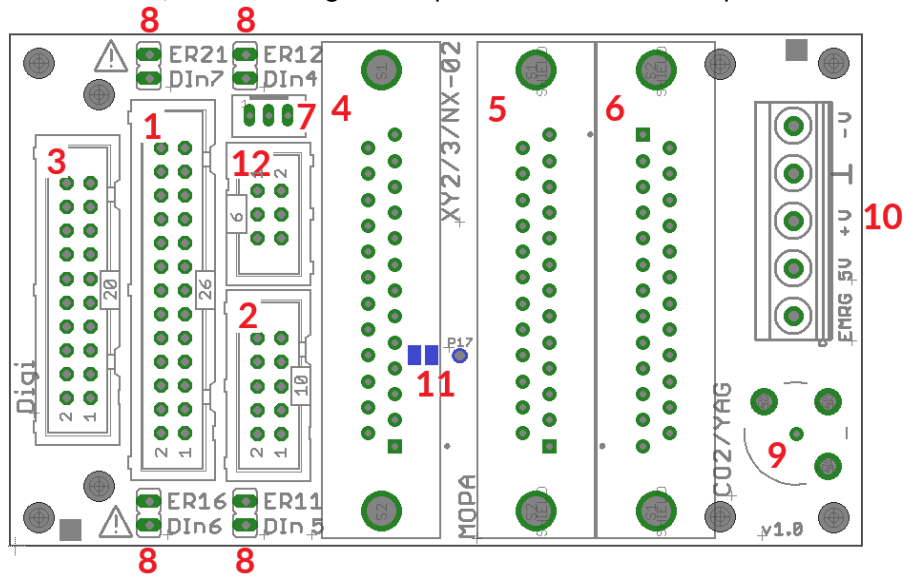

The connector provides following signals:

| Upper Row Of Pins | Signal | Voltage | Remarks             | Lower Row Of Pins | Signal | Voltage | Remarks             |
|-------------------|--------|---------|---------------------|-------------------|--------|---------|---------------------|
| 1                 | DATA+  |         | NX-02 output signal | 2                 | DATA-  |         | NX-02 output signal |
| 3                 |        |         | do not connect!     | 4                 |        |         | do not connect!     |
| 5                 |        |         |                     | 6                 |        |         |                     |
| 7                 |        |         |                     | 8                 |        |         |                     |
| 9                 |        |         |                     | 10                |        |         |                     |
| 11                |        |         |                     | 12                |        |         |                     |
| 13                |        |         |                     | 14                |        |         |                     |
| 15                |        |         |                     | 16                |        |         |                     |
| 17                |        |         |                     | 18                |        |         |                     |
| 19                |        |         |                     | 20                | GND    | GND     |                     |
| 21                | GND    | GND     |                     | 22                | GND    | GND     |                     |
| 23                |        |         | do not connect!     | 24                |        |         | do not connect!     |
| 25                |        |         |                     | 26                |        |         |                     |

Comparing to E1702S Baseboard this connector does not provide any laser signals (like LaserGate, LaserA or LaserB). Since this scanner output works completely parallel to the one from E1702S Baseboard it has to be used together with the same laser using beam splitters.

## 6.4 E1702Sdock Extension Board

The E1702Sdock is an expansion board which either can be mounted on very top of the E1702S (using hex-stands or distance bolts) or which can be mounted near to it (e.g. by using a second E170Xbase). It has to be wired with simple 1:1 flat-belt cables to the E1702S controller card. Dependent on which extension boards are available, the E1702Sdock provides some easy to use interfaces for connecting external equipment without the need to have own, complex wiring. Or in other words: when E1702Sdock is used, it acts as some kind of breakout-board, lasers and scanheads can be connected quite easy, only a few 1:1 cables need to be plugged.

 PLEASE NOTE: prior to using the E1702Sdock, please ensure the pinout of the connectors (as described below) really fit to your specific variant of your used laser. Elsewhere irreversible damage are possible at laser and/or scanner controller card.

PLEASE NOTE: when using the digital signals (from Digi IO extension board) in parallel, you need to ensure they are not used twice, out of both connectors. This may otherwise result in an undefined and unwanted behaviour as they work parallel and can't be switched separately. When a parallel usage is intended, please double-check the current consumption of connected devices as the total current that can be provided by these lines does not double but is the same total value for two connections then. Exceeding the total maximum allowed current of a E1702S-signal may cause an irreversible damage to the controller otherwise.

### 6.4.1 E1702Sdock Connectors

On top side the E1702Sdock provides the following connectors:

1. **E1702S baseboard input connector**

This connector has to be wired with a 1:1 connection to the E1702S baseboard (laser and scanner connector as described in section "6.1.9 Laser/Scanner Signals")

2. **E1702S NX-02 output connector**

This interface can be used to connect an NX-02 or SL2-100™ scanhead directly via a 1:1 connection when E1702S operates in NX-02 mode. It provides the following pinout:

| Pin | Description     | Pin | Description     |
|-----|-----------------|-----|-----------------|
| 1   | NX-02 DATA+     | 2   | NX02-DATA-      |
| 3   | Do not connect! | 4   | Do not connect! |
| 5   | Do not connect! | 6   | Do not connect! |
| 7   | Do not connect! | 8   | Do not connect! |
| 9   | Do not connect! | 10  | Do not connect! |

3. **E1702S Digi I/O input connector**

This connector has to be wired with a 1:1 connection to the Digi IO extension boards interface (as described in section "6.2.1 Digi I/O"); in case additional signals of the Digi I/O extension need to be used elsewhere, a flat-belt cable can be used that comes with three IDC-plugs on it. Then one plug can be connected to the Digi IO extension board, one to the E1702Sdock and one to some additional hardware making use of this interface. In this case please ensure no signals are double-used and no short-circuits are caused on input lines, otherwise the controller card, the E1702Sdock and/or the connected hardware may be damaged irreversibly!

The Digi I/O connector needs to be wired only in case

- a MOPA laser is connected and at least one of the alarm feedback signals is used or
- A YAG/CO<sub>2</sub> laser is connected and the shutter control signal is used



**PLEASE NOTE:** depending on the connected laser and the jumpers (8), some of the digital inputs are used from within the E1702Sdock! In this case the related signals should not be used for anything else, otherwise the controller card, the E1702Sdock and/or the connected hardware may be damaged irreversibly by a short-circuit! For more details please refer to the pinout of the laser connectors (5 and

6) and the description of the jumpers (8) below.

#### 4. XY2-100/XY3-100 output connector

In case the E1702Sdock is used with the E1702S controller card in XY2-100 or XY3-100 mode, this interface can be used to connect a XY2-100/XY3-100 scanhead directly. Here only a 1:1 D-SUB25 cable is needed. On this connector both, the XY2-100/XY3-100 signals as well as the optional power from the screw terminal (10) are provided. When a scanhead does not support power supply via the D-SUB25 cable, the power input at the screw terminal (10) can be left unused. This connector provides the standard pinout for XY2-100/XY3-100 connectors so that all compliant scanheads can be connected directly:

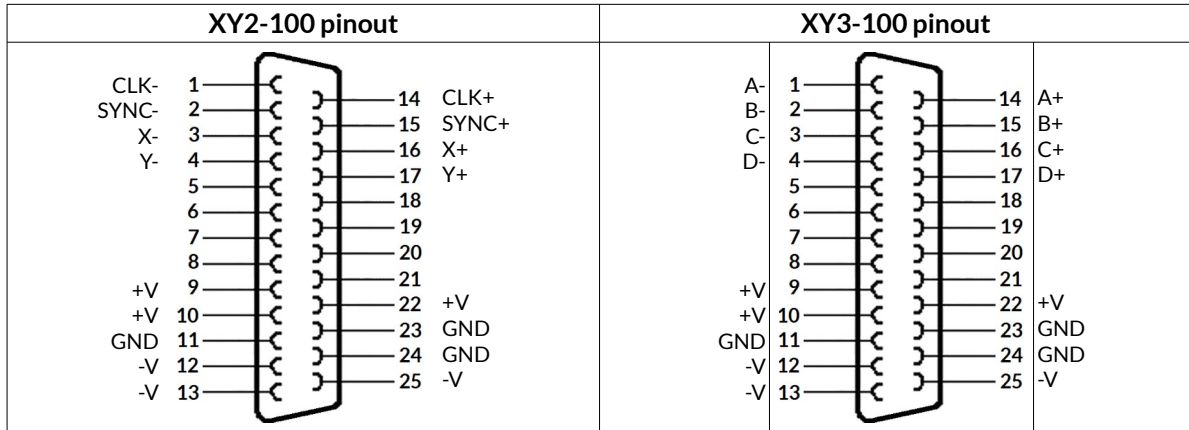

#### 5. MOPA laser output connector

This connector of the E1702Sdock can be used with most MOPA/fiber lasers such as IPG YLP interface types G (without SPI serial interface and pin 12 alarm signal), E (without APD indexing), D, D1, B, B1, MaxPhotonics MFP, JPT YDFLP, Raycus RFL-PMX, Raycus RFL-PQB, GZTech YFPN series and compatible laser types. Connection between E1702Sdock and laser is done mainly via a 1:1 D-SUB25 cable. The connector provides the following pinout:

| Pin | Description   | Pin | Description   |
|-----|---|-----|---|
| 1   | LP8_0 laser power signal, CMOS, max 8mA   | 14  | GND   |
| 2   | LP8_1 laser power signal, CMOS, max 8mA   | 15  | Not connected   |
| 3   | LP8_2 laser power signal, CMOS, max 8mA   | 16  | DIn6 laser alarm pin 16, available at DIn6 of Digi I/O extension only when jumper „DIn6/ER16“ is set (refer to description below) |
| 4   | LP8_3 laser power signal, CMOS, max 8mA   | 17  | Not connected   |
| 5   | LP8_4 laser power signal, CMOS, max 8mA   | 18  | MO main oscillator signal, CMOS, max 8mA  |
| 6   | LP8_5 laser power signal, CMOS, max 8mA   | 19  | LaserGate power amplifier signal, CMOS, max 14mA  |
| 7   | LP8_6 laser power signal, CMOS, max 8mA   | 20  | LaserA 5V pulse repetitive signal, CMOS, max 14mA   |
| 8   | LP8_7 laser power signal, CMOS, max 8mA   | 21  | DIn7 laser alarm pin 21, available at DIn7 of Digi I/O extension only when jumper „DIn7/ER21“ is set (refer to description below) |
| 9   | LP8 Latch laser power latch, CMOS, max 8mA  | 22  | Pilot signal used to switch the pilot laser, CMOS, max 14mA   |
| 10  | GND   | 23  | Emergency input, connected to screw connector (10), has to be pulled to HIGH for different laser types to enable operation        |
| 11  | DIn5 laser alarm pin 11, available at DIn5 of Digi I/O extension only when jumper „DIn5/ER11“ is set (refer to description below) | 24  | Not connected   |

|    |               |    |               |
|----|---------------|----|---------------|
| 12 | Not connected | 25 | Not connected |
| 13 | Not connected |    |               |

The signals on this connector are available only when LP8 extension and optionally Digi I/O extension is used.

#### 6. YAG/CO<sub>2</sub> laser output connector

This is a connector for direct connection to laser. A connection can be established using a standard 1:1 D-SUB-cable. This connector provides the following pinout which is typically to most common YAG or CO<sub>2</sub> lasers:

| Pin | Description   | Pin | Description  |
|-----|---|-----|--|
| 1   | Not connected   | 14  | Not connected  |
| 2   | Not connected   | 15  | Not connected  |
| 3   | GND   | 16  | Not connected  |
| 4   | Emergency input, connected to screw connector (10) and has to be pulled to HIGH for different laser types to enable operation           | 17  | GND  |
| 5   | GND   | 18  | GND  |
| 6   | GND   | 19  | GND  |
| 7   | Shutter control, this pin is connected to DOut7 of the Digi IO extension  | 20  | LaserB first pulse killer signal (FPK/QKILL for YAG lasers) or pilot laser output (for CO <sub>2</sub> lasers), CMOS, max 14mA |
| 8   | GND   | 21  | AOut1 power control, analogue signal in range 0..10V, max 15mA   |
| 9   | AOut0 frequency control, analogue signal in range 0..5V, max 15mA; this signal is hardware-divided by 2 comparing to the original AOut0 | 22  | LaserA 5V output, CMOS, max 14mA   |
| 10  | GND   | 23  | MO used to switch the pilot laser, CMOS, max 8mA   |
| 11  | GND   | 24  | LaserGate non-inverted/high-active laser-on signal, CMOS, max 14mA   |
| 12  | LaserGate inverted/low-active laser-on signal, CMOS, max 40mA   | 25  | LaserA negative +-5V output of differential PWM signal (PWM-, also connected to shield of BNC-connector/9)                     |
| 13  | LaserA positive +-5V output of differential PWM signal (PWM+, also connected to core of BNC-connector/9)                                |     |  |

All the signals on this connector are available only when the optional Digi I/O extension is used.

#### 7. Start/Stop input connector

This connector can be used only together with E1702S controller board and provides easy access to the ExtStart and ExtStop input pins (as described in section "6.1.9 Laser/Scanner Signals"). The connector requires a JST PH3P type plug and comes with following pinout:

|   |   |   |
|---|---|---|
| 1 | 2 | 3 |
|---|---|---|

1 - ExtStart input

2 - ExtStop input

3 - +5V output to be used with ExtStart and ExtStop

#### 8. MOPA alarm signal jumpers

These jumpers can be set when a MOPA laser is connected via (5) and the alarm feedback signal of this laser has to be used. For each of the lasers alarm lines that is intended to be read back, the related jumper has to be set (for details please refer to the pinout of connector 5 above and the manual of your laser).

PLEASE NOTE: when a jumper is set here, the related digital input of the Digi IO extension can't be



used as input any more! Doing so can cause a short-circuit and may damage the scanner controller card, the E1702Sdock and/or the external equipment feeding a signal into DIn5/DIn6/DIn7. Reading back the laser alarm signals requires the Digi IO extension

9. **BNC-connector for PWM/tickle-signal**

It provides a differential +5V LaserA signal which is also available as PWM+/PWM- at the D-SUB25 connector (pins 13 and 25 of connector 6) and which can be used for all PWM-controlled lasers such as YAG or CO<sub>2</sub>

10. **Power supply and enable signal connector**

This connector can be used to supply power to a connected XY2-100/XY3-100 scanhead. It has following pinout:

| Pin | Name     | Description  |
|-----|----------|--|
| 5   | -9..-30V | Power supply to scanhead, to be used only with E1701D controller board, is directly connected to pins 9, 10 and 22 of (4); this input voltage does <b>NOT</b> supply the controller board  |
| 4   | GND      | Common and scanhead ground, is directly connected to pins 11, 23 and 24 of (4)   |
| 3   | +9..30V  | Power supply to scanhead, to be used only with E1701D controller board, is directly connected to pins 12, 13 and 25 of (4); this input voltage does <b>NOT</b> supply the controller board   |
| 2   | 5V       | 5V output from scanner controller card, can be used e.g. to feed EMRG input (e.g. via contact of a relay). Please note: The "5V" pin of this screw connector is not allowed to be used for supplying power to any other peripherals. |
| 1   | EMRG     | Emergency/enable input for lasers, this pin is directly connected to pin 4 of YAG/CO <sub>2</sub> connector (6) and pin 23 of MOPA connector (5).  |

In case the three inputs 3, 4 and 5 are connected to a bipolar power supply providing +-12..+-30V to power the connected scanhead, the input voltage is feed to the scanhead directly via the XY2-100/XY3-100 connector but not to the scanner controller card. Here the input voltage has to be equal to the voltage required by the scanhead (typically +-15V or +-24V). Power supply needs to provide 1A plus current required for connected scanhead.

When no power supply with symmetric/bipolar outputs is available, it is possible to combine two standard power supplies. Here GND of the first power supply has to be connected with +V of the second power supply and with the GND-screw-connector of E1702Sdock according to following scheme:

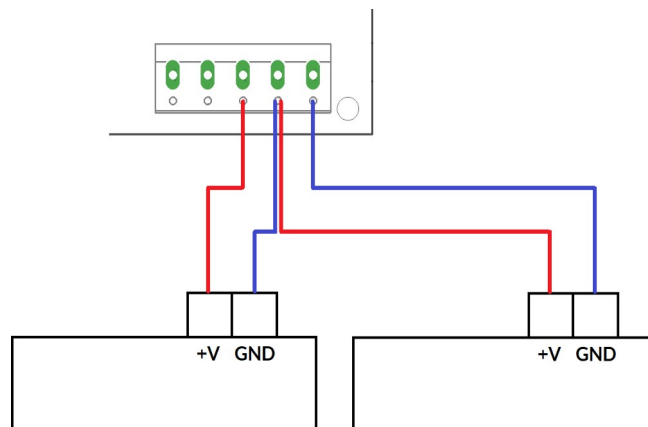

**ATTENTION:** When connecting wires to the screw terminals, do not transmit any force to the PCB where the green connector is soldered at! While screwing tight the wires, hold the connector by hand to catch the force but **do not hold the PCB only!**

11. On bottom side (marked in blue) there is a solder jumper "JP17" which applies +5V to pin 17 of the MOPA laser connector when closed. This jumper should be closed **ONLY** when the connected laser



expects a voltage input at this pin in order to operate some internal functions.

**ATTENTION:** Closing this pin when the connected laser does not expect this voltage input may cause irreversible damage to the hardware!

Right beside the solder jumper there is a pinhole which can be used to solder in a wire **when the solder jumper is not closed**. This pinhole, named as P17, is directly connected to pin 17 of the MOPA D-SUB25 connector. It can be used to apply any other, custom signal to that pin (depending on what the laser expects here).

**ATTENTION:** applying any other signal to P17 while JP17 is closed may cause a short circuit with the 5V rail of the controller and may cause irreversible damage to the hardware!

**When you are unsure about the usage of the JP17 solder jumper and/or the P17 wire soldering point, please contact HALaser Systems first!**

## 12. Power output connector

This is an additional connector which can be used to simplify power wiring of the E1702S. When power is applied to connector (10), the same power is provided as output at the pins of this connector. It can be used to establish a connection to the power input pins of the E1702S (as described in section “6.1.3 Power”). The power output connector provides the following pinout which allows a simple 1:1 connection to the power plug of the E1702S baseboard:

| Pin | Description | Pin | Description |
|-----|-------------|-----|-------------|
| 1   | +9..+30V    | 2   | +9..+30V    |
| 3   | GND         | 4   | GND         |
| 5   | -9..-30V    | 6   | -9..-30V    |

## 6.4.2 E1702Sdock Wiring

The E1702Sdock can be mounted on top of a E1702S-stack using hex-stands or distance bolts. E1702S is typically mounted on an E170Xbase (optional) to make use of a DIN-/C45-rail while the E1702Sdock is placed on very top. Connection between E1702S controller and its extension boards is done via short, 1:1 flat belt cables.

## 6.5 E170Xbase

The E170Xbase extension is a mounting help for easy installation on DIN rails/C45 rails and other possibilities of mechanical integration into machines:

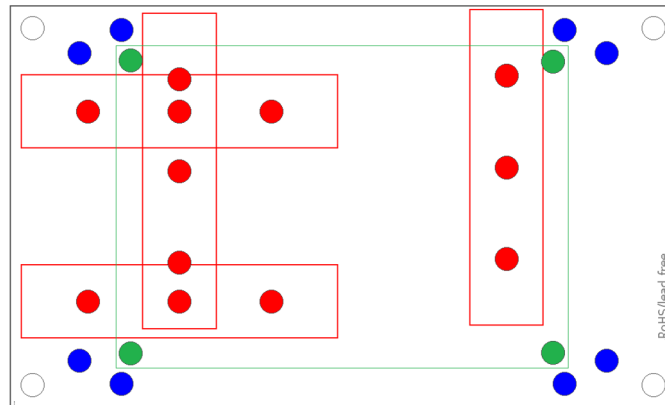

**RED** – mounting positions for DIN/C45 rail locks/DIN/C45 rail adapters (bottom side). Pairs of locks can be mounted in one of 2 possible orientations. Here locks of type Phoenix Contact 1201578 or similar can be used. With these locks the board then can be clamped on a DIN/C45 rail.

**BLUE** – mounting holes for the E1702S scanner controller card on top of the E170Xbase in one of two possible orientations. These holes are symmetrically arranged so that the board can be mounted by 180 degrees rotated. Here Hex stands/distance bolts with M3 threads (or similar) can be screwed in where the controller card is mounted on top.

**GREEN** – optional; mounting holes for a HALdrive converter board (top side) instead of an E170X scanner controller card, here Hex stands/distance bolts with M2 threads (or similar) can be screwed in where the HALdrive is mounted on top.

Mounting procedure for E170Xbase:

1. Identify suitable positions (**RED**) for two DIN/C45 rail locks and mount them on bottom side (two or three screws from top side into the lock on bottom)
2. Mount hex-stands or distance bolts in four of the given mounting holes (**BLUE**).
3. Mount E1702S on top of these hex-stands/distance bolts
4. Clamp the board on your DIN/C45 rail

Without the DIN/C45 rail clamps the board also can be used as top-cover for the E1702S.

## 7 Quick Start into E1702S

Following a few steps are described that give users the possibility to quick start into usage of E1702S scanner controller. It makes use of BeamConstruct and the (slow) USB connection. For this quick start manual it is assumed correct wiring of the controller is already done according to the description above. For more detailed information about BeamConstruct usage please also refer to quick start manual from [https://halaser.systems/download/manual\\_quickstart.pdf](https://halaser.systems/download/manual_quickstart.pdf) and to full user manual which is available at <https://halaser.systems/download/manual.pdf>.

To start with E1702S controller:



1. **SECURITY CHECK:** The following steps describe how to set up E1702S scanner controller card and how to control laser equipment with them. Thus all laser safety rules and regulations need to be respected, all required technical security mechanisms need to be available and active prior to starting with it.
2. Install latest software version from <https://halaser.systems/download.php> – for Windows this package contains all required drivers, for Linux no separate drivers are needed.
3. Connect E1702S controller via USB.
4. Now the Alive-LED should light up and then start blinking after some time. When this does not happen, please turn power off, check if the microSD-card is placed correctly and then try again.
5. Evaluate the serial interface the controller is connected with – for Windows the Device Manager (can be found in Control Panel) will list a new COM-port (e.g. “COM3”); for Linux type “dmesg” in console to find out to which interface it was connected with (typically “/dev/ttyACM0”).
6. Start BeamConstruct laser marking software.
7. Go to menu “Project” → “Project Settings...”, then tab-pane “Scanner”.
8. Now you can select “E1702S” as scanner controller card in the related combo box.
9. Press the “Configure”-button to get into the settings dialogue for E1702S plug-in.
10. Enter the serial interface name in field “IP/Interface” (e.g. “COM3” or “/dev/ttyACM0”).
11. Leave everything with “OK”.
12. Draw some geometries as described in “BeamConstruct Quick Start Manual”.
13. **SECURITY CHECK:** Next the scanner controller card will be accessed for the first time. That means it is opened and initialised and all connected equipment may start working now. Thus it is very important to ensure all security regulations are met and nobody can be injured and no damage can be caused also in case laser output or other motion starts spontaneously and unexpectedly!
14. Press “F2” or go to menu “Process” → “Mark” to open the mark dialogue.
15. Start marking by pressing the yellow button with the laser-symbol



## 8 Command Interface

When E1702 scanner card is connected via USB and the USB-connection is NOT used for transmitting marking information, it can be used to send control commands to the card. Some of them are independent of the current operating mode and some of them can be used only in case the controller is operating in stand-alone mode.

Beside the USB serial connection, these control commands can also be sent via Telnet using Ethernet connection. Here a Telnet-client has to connect to port 23 using the IP of the scanner controller. This Telnet client should work in passive mode. So when E1702 scanner card is connected via Ethernet and the Ethernet-connection is NOT used for transmitting marking information, it can be used to send control commands to the card. Some of them are independent of the current operating mode and some of them can be used only in case the controller is operating in stand-alone mode.

Such a control command always consists of ASCII-text. An appropriate client has to connect to the serial port (COMx for Windows and /dev/ttyACMx for Linux where "x" is a number identifying the specific serial interface or TCP/IP port 23). As soon as the connection is established, commands can be sent to the card. All commands come with following structure:

```
cxxxx <parameter(s)>
```

The commands always start with character "c". Next four characters identify the command itself. Depending on the command one or more optional or mandatory parameters may follow. The command always returns with an "OK" or with an error.

### 8.1 General Commands

The following commands can be used in all scenarios, they do not depend on a specific operation mode of the card. Nevertheless it is recommended to not to send commands excessively during card is marking, to not to influence marking operation.

```
cvers
```

"**version**" – return version information of the controller card. This command returns a version string specifying version of hard- and firmware in style **vFF-H** where "**FF**" is the version of the firmware and "**H**" specifies the hardware revision of the controller.

```
cecho <0/1>
```

"**echo**" – when typing commands in a serial console communicating with the controller, all the typed characters are echoed, means they are sent back to the host so that a user can see what is typed. This may be an unwanted behaviour when an application communicates with this interface. Using this command the serial echo mode can be turned off (parameter 0, only return values are sent back) or on (parameter 1, all data are sent back). When called with no parameters, the current echo mode value is returned.

Example: `cecho 0` – turn off echo mode

```
cgbds
```

"**get boards**" – get an identifier value for the connected boards. This command returns a decimal number which depends on the connected extension boards and can be used to identify them. The returned value is a sum consisting of the following numbers:

257 – XY2-100/XY3-100 baseboard (E1702S) is available

512 – Digi I/O Extension Board is available

```
cglog
```

"**get logline**" – returns a single logging line. This command has to be called repeatedly until an error is returned to get logging information from the controller. On each call of this function one logging line is returned. When "cglog" isn't used for a longer time it may be possible the internal log-buffer has overrun. In this case "cglog" will not return all log information, previous log data may be overwritten.

cgbsr

"get board serial number" – returns the serial number of the card. This number is an unique, internal value that is used e.g. to identify a controller on host PC when more than one scanner card is used.

## 8.2 Stand-Alone Control Commands

Following commands are useful in case scanner controller is operating in stand-alone mode where marking data are loaded from microSD-card using special EPR-fileformat.

cstop

"stop" – stop marking as fast as possible. A running marking operation is stopped and LaserGate is turned off.

chalt <0/1>

"halt" – halts or continues the processing and output of marking data. When given parameter is equal to 1, marking is stopped next time the laser is off but no vector data are dropped. On continue (parameter equal 0) controller continues processing at the point where halt occurred. When marking is stopped with `cstop` the halt-condition is cleared too, means on next transmission of new marking data they are processed without the need to explicitly continue operation by calling `chalt 0`.

cstrt

"start" – start marking operation. This command can be called only when no marking operation is running and when a valid project (.epr) file was loaded. In this case the currently loaded project is marked once.

ctrig

"trigger" – send an external trigger signal by software. When scanner card is in state "marking" but waiting for an external trigger, this command releases this trigger. So behaviour is the same like a rising edge on the ExtStart input of the controller card.

cstat

"state" – return the current state of the card. This command returns one of the following texts identifying the operational state:

- `marking` – card is processing some marking data currently, means either actively outputting them or waiting for an external trigger to start marking
- `stand-alone` – controller is in stand-alone mode
- `idle` – card is waiting and not marking
- `waiting` – a project file was loaded, is ready for execution and waits for a trigger signal (either via ExtStart input or via command "ctrig")

cxnc

"execute CNC data" – switch to a mode where G-Code process data are accepted via Telnet/serial interface. When this command is set, the G-Code reception mode stays active until a command "M2" (end of G-Code program) is detected. Only with M2 received, the controller returns to normal operation mode and again accepts native "c"- and "d"-commands.

This command can be used to send CNC-commands to the controller in order to let them be executed automatically like some direct control commands. These G-codes are executed like a stream of commands. So "cxnc" provides an other possibility to send operation data to the controller. When enough data have provided to the controller, it starts marking automatically. In case of only very few CNC data that aren't enough to let the controller start marking, this is done at the end of the CNC stream of data: after all the available G-Code data have been transferred and transmission has been ended with "M2", marking of these data is started. To successfully send G-Code data, some preconditions have to be met. For data transmission via Telnet:

- a G-Code line is limited to 255 characters maximum and always has to end with carriage return and/or line feed

- when transferring more than one line at the same time, the maximum packet size is 1460 bytes, at the end of such a packed a G-Code line has to end too and it is recommended to flush the full output buffer in order to invoke a data transmission over TCP/IP; this procedure is recommended in order to have an as fast as possible data transfer independent from the implementation a TCP/IP stack really uses

For data transmission via USB serial interface:

- a G-Code line is limited to 255 characters maximum and always has to end with carriage return and/or line feed

The structure and supported G-Code commands are described in section “9 Supported CNC G-Code Commands” below.

This function requires firmware version 4 or newer.

`cgtin`

**“get trigger inputs”** - get the state of the external input signals. This command is not related to digital inputs of Digi I/O extension board but provides information regarding signal state of external start and stop. It returns a value that specifies which of these input signals are currently HIGH:

0 - ExtStart and ExtStop are both LOW

2 - ExtStart is HIGH

4 - ExtStop is HIGH

6 - ExtStart and ExtStop are both HIGH

`cscor <idx>`

**“set correction”** - specifies a new index for a previously loaded correction file (see description of configuration parameter `corrtable` in section “6.1.8 microSD-Card” above). The parameter `idx` can be a value in range 0..15 and needs to correspond to a previously loaded correction table. The newly set correction table applies to all vector data which are processed after this call. Thus it is recommended to use it only when marking operation was stopped - elsewhere it is not predictable how many vector data already have been pre-calculated with the previous correction table and starting with which vector data the new correction file is used.

When a `idx`-value is set which corresponds to no correction file data, no more correction is performed on vector data.

`cgcor`

**“get correction”** - this command is the counterpart of `cscor` and displays the index number of the currently used correction file

`clepr <path>`

**“load epr”** - loads an EPR stand-alone file from microSD card for outputting it on next marking operation. This command can be executed in stand-alone mode only.

When operating in stand-alone mode “`idxselect`”, the command expects a number as parameter which specifies the index file to be loaded.

When operating in stand-alone mode “`ioselect`” or “`iohaltedloop`”, the command is not supported.

When operating in any other stand-alone mode, the command expects the path to the file to be loaded as parameter. Since this is the only parameter, no quotes are allowed for the pathname. The pathname itself has to be in format

`0:/filename.epr`

where `0:/` specifies the microSD-card and `.epr` is the standard extension of E1702 stand-alone marking data files (this name is a shortcut for “E1702 Processing Data”). During loading the ready-for-marking output signal is turned off and it is turned on only in case the file could be loaded successful (please refer to related section above).

Examples: `clepr 0:/test.epr` - loads a stand-alone file “test.epr” from microSD card

`cgep`

**“get epr”** - returns the name of the currently loaded stand-alone file or an error “no file specified” when no file is loaded.

`cdepr <path>`

**"delete epr"** - deletes an EPR stand-alone file and all related, additional files from microSD card. This command can be executed in stand-alone mode only.

When operating in stand-alone mode "idxselect", the command expects a number as parameter which specifies the index file to be loaded.

When operating in stand-alone mode "ioselect" or "iohaltedloop", the command is not supported.

When operating in any other stand-alone mode, the command expects the path to the file to be delete as parameter. Since this is the only parameter, no quotes are allowed for the pathname. The pathname itself has to be in format

`0:/filename.epr`

where `0:/` specifies the microSD-card and `.epr` is the standard extension of E1702 stand-alone marking data files (this name is a shortcut for "E1702 Processing Data"). Deleting is done asynchronously, so the returned "OK" only verifies the command was accepted. Successful deletion of the file can be assumed after 0,5 seconds.

Examples: `cdepr 0:/test.epr` - deletes a stand-alone file "test.epr" from microSD card. When additional files `test.dat` (which may contain related dynamic data) and `test.ser` (which may hold serial number information) exist, they are deleted by this command too.

`csbuf <idx> <path>`

**"set buffer"** - this command works similar to the configuration parameter "iobuf" and can be called in stand-alone modes "ioselect" and "idxselect". It can be used to preload EPR stand-alone data files into memory so that they can be accessed faster and without additional accesses of the SD card. The first parameter `<idx>` is mandatory and specifies the slot the EPR file has to be loaded to. Different to parameter "iobuf" where the slot number is given automatically and where the index value can be in range 1..255, here the slot number and the index number are always the same and are in range 1..20. So only the first 20 index values can be used together with this dynamic loading function. When only `<idx>` is given, the loaded file is `0:/<idx>.epr`. Optionally also a file name `<path>` can be given in format `0:/file.epr`. In this case the given file is loaded to the slot specified by `<idx>` and can be accessed with the related index number. After every call to `csbuf` the command `cgbuf` has to be executed repeatedly until it returns -1.

Examples:

`csbuf 3` - loads the file `0:/3.epr` from SD-card and stores it in slot number 3 so that it can be accessed either via "`clepr 3`" (in stand-alone mode "idxselect") or via a digital input pattern at the Digi I/O Extension representing a 3 (in stand-alone mode "ioselect")

`csbuf 5 0:/markme.epr` - loads the file `0:/markme.epr` from SD-card and stores it in slot number 5 so that it can be accessed either via "`clepr 5`" (in stand-alone mode "idxselect") or via a digital input pattern at the Digi I/O Extension representing a 5 (in stand-alone mode "ioselect")

`cgbuf`

**"get processed buffer"** - returns the index number of the buffer that is currently processed by a previous call to `cgbuf`. As long as this command returns a value greater than -1, no other calls to `csbuf` are allowed. The returned number specifies the index/slot number that is currently filled with data. When `cgbuf` returns -1, the loading operation has been finished.

`cjsor <percentage>`

**"jump speed override"** - changes the speeds of all jump speed values by the given factor. Here parameter `percentage` has to be given in unit 1/100%. The override-value specified by this command remains active until it is set back to normal value by calling "`cjsor 10000`" or until the controller is rebooted. The value given here is active for all processed data including host-controlled marking projects and stand-alone files loaded from microSD card.

`cmsor <percentage>`

“**mark speed override**” – changes the speeds of all mark speed values by the given factor. Here parameter `percentage` has to be given in unit 1/100%. The override-value specified by this command remains active until it is set back to normal value by calling “`cmsor 10000`” or until the controller is rebooted. The value given here is active for all processed data including host-controlled marking projects and stand-alone files loaded from microSD card.

`cpwor <factor>`

“**power overwrite**” - this command modifies the actual power by using the given factor (in unit 1/100%). All operations make use of the changed power until a factor of 10000 is set or until the controller is restarted. This is true for both, stand-alone applications where an .EPR-file is loaded from microSD-card and for host-controlled marking operations (via `libe1702` or `BeamConstruct`).

This command influences following methods of setting laser power:

- pulse width, here user has to ensure the resulting pulse width is smaller than the period of the related frequency, elsewhere the output will be a continuous signal
- LP8 laser port

`cfror <factor>`

“**frequency overwrite**” - this command modifies the actual frequency by using the given factor (in unit 1/100%). All operations make use of the changed power until a factor of 10000 is set or until the controller is restarted. This is true for both, stand-alone applications where an .EPR-file is loaded from microSD-card and for host-controlled marking operations (via `libe1702` or `BeamConstruct`).

This command is not available for laser modes CO<sub>2</sub> or YAG

`cpuor <factor>`

“**pulse-width overwrite**” - this command modifies the actual pulse-width by using the given factor (in unit 1/100%). All operations make use of the changed pulse-width until a factor of 10000 is set or until the controller is restarted. This is true for both, stand-alone applications where an .EPR-file is loaded from microSD-card and for host-controlled marking operations (via `libe1702` or `BeamConstruct`).

This command is not available for laser modes CO<sub>2</sub> or YAG, there the pulse-width is changed via command `cpwor`.

`cgmtx`

“**get matrix**” - return the four elements of the 2x2 output matrix. The members of the matrix are returned as four integers with a factor of 1000. So returned values of “1200 0 0 1200” are equal to a matrix

|     |     |
|-----|-----|
| 1,2 | 0,0 |
| 0,0 | 1,2 |

Which itself defines a scale factor of 1,2 in both, X and Y direction of the output.

`csmtx <m11 m12 m21 m22>`

“**set matrix**” - set a 2x2 matrix which is used for the global output of the scanner card. This means, the values applied here influence the whole project which is currently be marked. Such a 2x2 matrix can be used to modify the X- and Y-scale, the rotation and the X- and Y-slant of the output. The matrix members `m11`, `m12`, `m21` and `m22` have to be given as integers which represent the matrix elements multiplied by 1000.

As soon as a custom matrix is set via this command, all matrix values out of a loaded EPR file are ignored and only the matrix-values currently set are used. This includes gain and rotation correction settings which may be set in such an EPR file.

Example: `csmtx 996 -87 87 996` – rotate the output by 5 degrees; these values are generated out of the unity matrix {1000, 0, 0, 1000} which was multiplied with the rotation matrix { $\cos(5)^*1000$ ,  $-\sin(5)^*1000$ ,  $\sin(5)^*1000$ ,  $\cos(5)^*1000$ }

`cswaf <factor>`

Sets a factor in unit bits per mm that is used with all commands that specify some distance or position (such as `cspof`). When this factor is set to a proper value, the given positions/distances can be specified in unit um instead of bits. When a factor of 1000 is specified, the functionality is reset back to the default behaviour where position values have to be given in unit bits.

This parameter requires a firmware version 2 or newer.

`cspof <x y z>`

**"set position offset"** – sets a n position offset for the complete output. This function expects three parameters for the offset to be set in X, Y and Z-direction. The values to be given here are signed 26 bit, means they need to be in range -33554431..33554432. To reset the offset for one or more directions, a value of 0 has to be set. Please note: this offset is set prior to the matrix calculations which may be done when a custom output matrix is set using command `csmtx`. Resulting from that, the matrix calculation also applies to the offset defined here. So when the matrix e.g. defines a scale factor for the output, the offset values specified here are scaled by the same factor.

Example: `cspof -16777216 0 0` – shift the output by a quarter of the whole available working area to the left.

`csser <"elementname"> <cnt>`

**"set serial number"** – sets a new serial count value to an element in currently loaded project. The element name for this command has to be given with quotes (""). Setting a new count is possible only for dynamic elements like Datamatrix barcodes or texts that have a serial number input element assigned. Setting the value has to be handled with care, here every value can be specified independent if it fits to possibly existing beat count values.

Example: `csser "Text 2" 42` – set a new serial number count value 42 for element with the name "Text 2"

`cgser <"elementname">`

**"get serial number"** – gets the current serial count value from an element in loaded project. The element name for this command has to be given with quotes (""). Getting the count is possible only for dynamic elements like Datamatrix barcodes or texts that have a serial number input element assigned.

`ciser <"elementname">`

**"increment serial number"** – increments the current serial count value of an element according to its serial number parameters. The element name for this command has to be given with quotes (""). Incrementing the count is possible only for dynamic elements like Datamatrix barcodes or texts that have a serial number input element assigned. This function is more secure than forced setting of a new count value with "csser" since it can't violate the counting rules.

`cdser <"elementname">`

**"decrement serial number"** – decrements the current serial count value of an element according to its serial number parameters. The element name for this command has to be given with quotes (""). Decrementing the count is possible only for dynamic elements like Datamatrix barcodes or texts that have a serial number input element assigned. This function is more secure than forced setting of a new count value with "csser" since it can't violate the serial number counting rules.

`crser <"elementname">`

**"reset serial number"** – resets the current serial count value of an element to its start-value (according to its serial number parameters). The element name for this command has to be given with quotes (""). Resetting the count is possible only for dynamic elements like Datamatrix barcodes or texts that have a serial number input element assigned. This function is more secure than forced setting of a value with "csser" since it can't violate the predefined serial number parameters and automatically uses the correct reset value.

`cstim <seconds>`

**"set time"** – this command sets the system time to the value specified with the parameter. Here the

number of seconds have to be specified that have elapsed since 01.01.1970 at 00:00:00. After sending this command the controller card operates at the given time. The time value is lost after next power cycle and has to be set again.

Example: `cstim 1420113600` – set the internal time of E1702 controller to 01.01.2015 12:00:00, here 1420113600 represents the number of seconds that have been elapsed between 01.01.1970 00:00:00 and 01.01.2015 12:00:00

`crtim`

**"retrieve time"** – this command schedules time retrieval from an SNTP server asynchronously. It always returns with "OK" since the command is scheduled for execution during next working cycles. To use this command, controller has to be configured with IP, netmask, gateway and SNTP server IP correctly and needs to be able to access this SNTP server from its position in network. For details please refer to description of configuration parameters in section about microSD card above.

`cgtim`

**"get time"** – returns the current time of the board in number of seconds that have elapsed since 01.01.1970 at 00:00:00. After powering up the board and before a valid time has been set, this value is undefined.

`cftim`

**"get formatted time"** – returns the current time of the board as formatted string in style DD.MM.YYYY hh:mm:ss. After powering up the board and before a valid time has been set, this value is undefined.

`cstyr <year>`

**"set time year"** – sets the year of the current system time to the value given as parameter. This value has to be in range 1900..2038

`cstmo <month>`

**"set time month"** – sets the month of the current system time to the value given as parameter. This value has to be in range 1..12 according to the number of the month.

`cstdy <day>`

**"set time day"** – sets the day of the current system time to the value given as parameter. This value has to be in range 1..28, 1..30 or 1..31 according to the length of the current month. To avoid invalid combinations it is recommended to set the month (using command `cstmo`) before setting the day.

`csthr <hour>`

**"set time hour"** – sets the hour of the current system time to the value given as parameter. This value has to be in range 0..23.

`cstmi <minute>`

**"set time minute"** – sets the minute of the current system time to the value given as parameter. This value has to be in range 0..59.

`cstsc <second>`

**"set time second"** – sets the second of the current system time to the value given as parameter. This value has to be in range 0..59.

`cgsta`

**"get serial state"** – this command applies only when working in stand-alone mode with dynamic serial number data that change on every mark operation. It returns information if the state of serial numbers has

changed and is not yet saved (in this case "pending" is returned) or if they have been saved and therefore do not get lost when power is turned off now ("saved" is returned in this case).

`cssta`

**"save serial state"** - this command applies only when working in stand-alone mode with dynamic serial number data that change on every mark operation. When it is called, a command to save the current state of serial numbers is enqueued and will be processed as soon as controller is able to store these data. So when this command returns with "OK" that doesn't necessarily means the serial number states are saved now. The current save state still has to be checked by calling `cgsta` after `cssta` has been issued.

`crrrr`

**"reboot"** - perform a warm reboot of the hardware and restart the firmware. Reboot is done immediately, means this command does not return anything but connection to the board will be interrupted as soon as it has been sent.

## 8.2.1 EPR specific commands

The following commands and their syntax applies to stand-alone modes with an EPR file loaded.

`cstxt <"elementname"> <"text">`

**"set text"** - set a new text value to an element in currently loaded project. The parameters for this command both have to be given with quotes ("). Setting a text is possible only for dynamic elements like Datamatrix barcodes or texts. Here "elementname" is the name of the element that has to be modified (this is the same name like shown in element tree of BeamConstruct) and the new text to be set. The "text" itself can be a format string as used within BeamConstruct when a serial number input element is involved  
Example: `cstxt "Barcode 1" "Hello :-)"` - sets a new text "Hello :-)" for the element with name "Barcode 1"

`cgtxt <"elementname">`

**"get text"** - gets the currently used text value of an element in loaded project. The parameter for this command has to be given with quotes ("). Getting a text is possible only for dynamic elements like Datamatrix barcodes or texts.

Example: `cgtxt "Barcode 1"` - gets the text from the element with name "Barcode 1"

## 8.2.2 BEAMP specific commands

The following commands and their syntax applies to stand-alone modes with an BEAMP file loaded. These commands require a firmware version 3 or higher.

The following commands all are related to specific elements within a loaded .BEAMP project file. So to modify properties of these elements, they first have to be selected:

`csele <elementname>`

**Select an element** by using the name it has within the BEAMP project file. Only when an element is selected, it can be modified by one of the element-specific commands as specified below.

Example: `csele Text 3` - selects the element out of the BEAMP project file that has the name "Text 3". All further element-specific commands will be applied to this text element.

`ctrnx <x>`

`ctrny <y>`

`ctrnz <z>`

**Translate** a selected element by the given amount of micrometers in x/y/z direction

crotx <x>  
croty <y>  
crotz <z>

**Rotate** a selected element by the given amount of 1/1000 degrees around the x/y/z axis

csclx <x>  
cscl y <y>  
csclz <z>

**Scale** a selected element by the given factor which comes with a resolution of 1/1000, so a value of 1000 is equal to a factor of 1.0 which means no scaling

cslyx <x>  
cslzx <y>  
cslxy <z>  
cslzy <z>  
cslxz <z>  
cslyz <z>

**Slant** a selected element by the given factor of 1/1000's along the yx/zx/xy/zy/xz/yz axis

cstxt <text>

**"set text"** – set a new text value to the currently selected element. This function can be used only with elements that are able to accept texts, such as Text or Barcode primary elements

cgtxt

**"get text"** – gets the currently used text value of the selected element. This command can retrieve a text only from element types, which internally hold some text data, such as Text or Barcode primary elements

## 8.3 Hardware Commands

These commands can be used to access hardware signals directly. When these hardware outputs are set or unset while a marking operation is running, they may have no effect as they may be overridden immediately. Thus it is recommended to execute them only when the controller card is idle and no other operations are in progress. But also in this case, when a hardware output is set to a specific state, any operation (especially marking cycle) that is executed afterwards, may override that specific state-changes. Following hardware-specific commands are supported:

cginp

**"get input"** – get the current state of the digital inputs (in case a Digi I/O extension is available). The input state is returned as a decimal number representing the bitpattern at the inputs. So when e.g. a value "15" is returned, this means the lower four inputs are set to HIGH while the upper ones are at LOW level

csout <value>

**"set output"** – set the state of the digital outputs (in case a Digi I/O extension is available). The output to be set is specified as a decimal number representing the bitpattern. When no parameter is given, the behaviour is undefined.

Example: `csout 128` – set DOut7 at the Digi I/O extension board to HIGH while all others stay at LOW

cslgt <value>

**"set LaserGate"** – set the state of the LaserGate output either to HIGH (value is set to 1) or to LOW (value is set to 0).

cslmo <value>

“set **MO**” – set the state of the main oscillator output either to HIGH (value is set to 1) or to LOW (value is set to 0).

cspil <value>

“set **pilot**” – set the state of the dedicated pilot laser output either to HIGH (value is set to 1) or to LOW (value is set to 0).

This command requires firmware version 4 or newer.

cslp8 <value>

“set **LP8**” – set the state of the LP8 output port to the value given as parameter. Here value is allowed to be in range 0..255, the related bits of the LP8 output are set according to the bitpattern of the specified number.

## 8.4 Mark Control Commands

The following section describes commands that can be used to send marking data (including vector data and laser/scanner parameters) to the controller. These commands can be mixed with the commands described above but have a different structure:

- they always start with a character "d"
- the total length of one frame (means one command) is always 14 bytes
- they mustn't be terminated with CR/LF, the end of a frame is determined by its size of 14 bytes
- they contain binary, means not human-readable data and therefore can't be sent manually

Different to the programming interface (“10.1 E1702 Easy Interface Functions”) mentioned below, this possibility to send control and marking data is completely independent from any host operating system and from any additional software or libraries. It gives the possibility to send marking data to the card right via some binary data which can be sent via Ethernet connection (Telnet) or USB serial interface.



**PLEASE NOTE:** when using Network/Telnet connection and when switching from a Mark Control Command ("d"-command) to a general command ("c"-command as described above) it is recommended to completely transmit all preceding output before sending a command of other type.

These commands always have the following structure:

dCAAAABBBBBEEEE

d – marks starting point of a frame and identifies a mark control command with a fixed length of 14 bytes (including this character)

C – 8 bit value that specifies what command has to be executed

AAAA – 32 bit little-endian value, it's meaning and usage depends on "C"

BBBB – 32 bit little-endian value, it's meaning and usage depends on "C"

EEEE – 32 bit little-endian value, it's meaning and usage depends on "C"

It is recommended to collect commands before they are sent to the controller, especially in case Ethernet connection is used. In case of TCP/IP the used payload length of a TCP-frame is 1460 bytes which should be filled as much as possible in order to avoid additional data transfers. So when sending larger amounts of data to the controller, up to 104 command frames should be collected and then sent all together (104 \* 14 = 1456 bytes which is close to 1460).

From time to time the controller sends back an answer to give back some state information. In case of Ethernet/Telnet connection this answer is not sent periodically but as response to a complete block of data sent to the card. Since the size of such a block is not specified and depends on the underlying TCP/IP implementation (in case of Ethernet connections), no predictions can be made after what amount of data a response frame is sent. Thus it is recommended to try to receive such a response frame every time some data have been transmitted until at least one frame was received. When host software is idle, it can try to read response frames

permanently. To trigger transmission of a new response frame, "ping" control command 0x0A can be used (for details please refer below).

In case of USB/serial connection this response is sent automatically after every 14 byte frame submitted, so it is necessary to always read them in order to avoid overrun of receive buffers.

Such a response frame gives back information about the current operational state of the card and comes in following structure:

dRLLLLSSSSI III

d - marks starting point of a response frame with a fixed length of 14 bytes (including this character), this character can be used to re-synchronise

R - 8 bit value, currently always 0xFF; this value has to be checked for future compatibility, in case it is not 0xFF the frame has to be ignored!

LLLL - 32 bit little-endian value, here the amount of free command buffer space is returned; sending application has to ensure this buffer never overruns, so it is recommended to always leave a space of at least 200 commands (recommended: 1000), new commands should be sent only when there is more space than this left in this buffer

SSSS - 32 bit little-endian value, signalling operational state; this value can consist of following or-concatenated flags:

- 0x00000001 - card is currently marking
- 0x00000002 - the external start input is currently HIGH
- 0x00000004 - the external stop input is currently HIGH
- 0x00000008 - the external start input was set to HIGH after last response frame, this value is set only once for every rising edge on this input
- 0x00000010 - the external stop input was set to HIGH after last response frame, this value is set only once for every rising edge on this input
- 0x00000080 - the controller has received some data which may result in a marking operation; these data are currently processed but marking has not yet started
- 0x00000400 - card is active but currently waiting for an external trigger to continue operation
- 0x00004000 - card is active, writing some data to the microSD card

IIII - 32 bit little-endian value, lower 8 bit show the actual state of digital inputs (in case Digi I/O Extension Board is available), the upper 24 bits are reserved for future use.

Currently following mark control commands (identified by the 8 bit hexadecimal value for position "C" in a frame) can be sent to the controller:

#### Jump to Position

Move to a given coordinate position using the current jump speed and with laser turned off

C = 0x00

AAAA = x-position to move to in range 0..67108863

BBBB = y-position to move to in range 0..67108863

EEEE = z-position to move to in range 0..67108863

#### Mark to Position

Move to a given coordinate position using the current mark speed and with laser turned on

C = 0x01

AAAA = x-position to move to in range 0..67108863

BBBB = y-position to move to in range 0..67108863

EEEE = z-position to move to in range 0..67108863

#### Start output

This command has to be called at the end of every marking sequence to ensure marking output really starts. This is important in case only a few vectors are sent to ensure marking is started but it is recommended to always use this command.

C = 0x02

AAAA = unused, set to 0  
BBBB = unused, set to 0  
EEEE = unused, set to 0

#### Wait for external trigger

Set a trigger point to current position of stream; emission of output data will stop until an external trigger signal is detected

C = 0x03

AAAA = unused, set to 0

BBBB = unused, set to 0

EEEE = unused, set to 0

#### Set speed values

Specify the speeds to be used during jump or mark movements (invoked by commands 0x00 and 0x01)

C = 0x04

AAAA = jumpspeed in unit bits per microsecond

BBBB = markspeed in unit bits per microsecond

EEEE = unused, set to 0

#### Set laser delays

Specify the delays to be used when laser is turned on or off

C = 0x05

AAAA = laser on delay in unit microseconds and in range -10000000..10000000

BBBB = laser off delay in unit microseconds and in range 0..10000000

EEEE = unused, set to 0

#### Set scanner delays

Specify the delays to be used before and after mark and within a polygon

C = 0x06

AAAA = jumpdelay in unit microseconds

BBBB = markdelay in unit microseconds

EEEE = in-polygondelay in unit microseconds

#### Stop marking

Tries to halt, continue or stop current output depending on the chosen option

C = 0x07

AAAA = stop option:

0 - tries to stop operation as fast as possible and rejects all data that still may be enqueued for execution

1 - marking is stopped next time the laser is off but no vector data are flushed, card is still active

2 - controller continues processing at the point where halt occurred (requires a previously called command 0x07 with stop option 1)

BBBB = unused, set to 0

EEEE = unused, set to 0

#### Set wobble parameters

Specify the wobble settings to be used for next marking operations

C = 0x08

AAAA = wobble amplitude in X-direction using unit bits and with maximum range of 0..10000000 bits

BBBB = wobble amplitude in Y-direction using unit bits and with maximum range of 0..10000000 bits

EEEE = wobble frequency in unit Hz\*100 and in range 1..2500000

#### Set LP8 outputs

### Set LP0..LP7 output pins

C = 0x09

AAAA - bitpattern to be set on LP0..LP7 output pins, here only lower 8 bits are used.

BBBB = unused, set to 0

EEEE = unused, set to 0

### Ping

This command can be used to let the controller send back a state-information. So it can be used to check if the card is still operating or not.

 **ATTENTION:** this command should not be sent repeatedly and without any delay! This could cause E1702S scanner controller to stall because the massive data transfer has to be handled. So it is recommended to have a delay of at least 150 msec between every ping.

C = 0x0A

AAAA - unused, set to 0

BBBB = unused, set to 0

EEEE = unused, set to 0

### Set digital outputs

Set DOut0..DOut7 output pins on Digi I/O Extension Board

C = 0x0B

AAAA - bitpattern of the bits to be set on DOut0..DOut7 output pins, here only lower 8 bits are used.

BBBB - bitpattern of the bits to be cleared on DOut0..DOut7 output pins, here only lower 8 bits are used.

EEEE = unused, set to 0

### Set lasermode

Specify the laser mode the card has to operate with

C = 0x0C

AAAA - flags specifying the laser mode, here following values have to be or-concatenated to specify the behaviour of a laser:

- 0x40000000 - laser frequency on LaserA output is turned on immediately and together with laser gate signal, this flag can't be used together with 0x20000000
- 0x20000000 - laser frequency on LaserA output is turned on after FPK time, this flag can't be used together with 0x40000000
- 0x10000000 - laser supports FPK on LaserB output
- 0x08000000 - laser frequency has to be turned off and switched to standby-frequency
- 0x04000000 - a frequency can be emitted at LaserB permanently, the related frequency can be specified with command 0x15.

Using these flags following laser types can be configured:

- CO2-laser:  
0x40000000 + 0x08000000
- YAG-laser with FPK:  
0x40000000 + 0x08000000 + 0x10000000 or  
0x20000000 + 0x08000000 + 0x10000000
- laser with continuously running frequency: 0x40000000

BBBB = unused, set to 0

EEEE = unused, set to 0

### Set marking on-the-fly parameters

Specify the parameters used for marking on-the-fly applications

C = 0x0D

AAAA = marking on-the-fly resolution in X-direction in unit bits per encoder increment

BBBB = marking on-the-fly resolution in Y-direction in unit bits per encoder increment

EEEE = unused, set to 0

#### Set laser frequency

Specify the frequency the laser has to be operated with during marks, usage of these parameters depends on the lasermode specified with command 0x0C

C = 0x0E

AAAA = frequency in unit Hz and in range 25..20000000 Hz

BBBB = pulse-width in unit microseconds and in range 1..65530 usec

EEEE = unused, set to 0

#### Set laser standby frequency

Specify the frequency the laser has to be operated with during jumps, usage of these parameters depends on the lasermode specified with command 0x0C

C = 0x0F

AAAA = frequency in unit Hz and in range 25..20000000 Hz

BBBB = pulse-width in unit microseconds and in range 1..65530 usec

EEEE = unused, set to 0

#### Set first pulse killer

Specify the pulse width of the FPK signal when laser is turned on, usage of these parameters depends on the lasermode specified with command 0x0C

C = 0x11

AAAA = FPK pulse width in unit microseconds\*100

BBBB = the time the laser frequency has to be started after beginning of FPK using unit microseconds\*2, this value is used only when lasermode flag 0x20000000 is set

EEEE = unused, set to 0

#### Switch MO-output

Turns the MO-output on or off

C = 0x12

AAAA = turn MO output on when equal 1, turn it off when 0

BBBB = unused, set to 0

EEEE = unused, set to 0

#### Release external trigger

When card is waiting for an external trigger this command can be sent to release this external trigger by software and to continue execution without the need to receive a real external signal

C = 0x13

AAAA = unused, set to 0

BBBB = unused, set to 0

EEEE = unused, set to 0

#### Wait for external input signal

Stop execution until a defined input bitpattern is detected at configurable input pins DIn0..DIn7 of Digi I/O Extension Board

C = 0x14

AAAA = a bitpattern specifying which signals LOW or HIGH have to be detected at digital input pins

BBBB = a bitpattern specifying which of the digital input pins have to be watched for a signal, these bits that are set to 0 are ignored while these bits, that are set to 1 have to get the state specified in previous parameter in order to let operation of card continue

EEEE = unused, set to 0

#### Set LaserB frequency

Specify the frequency LaserB output has to emit; this function can only be used when operating using a laser mode with flag 0x04000000 set (see command 0x0C above).

C = 0x15

AAAA = frequency in unit Hz and in range 25..20000000 Hz  
BBBB = pulse-width in unit microseconds and in range 1..65530 usec  
EEEE = unused, set to 0

Wait until on-the-fly-increments have been elapsed

This command adds some special kind of delay to the application. It can be used only when marking on-the-fly is enabled (by setting the on-the-fly factors), and halts laser marking not for a given time but for a given distance. Marking is continued only when the given number of increments has elapsed. When no or not enough increments are counted by the controller, operation only can be stopped.

C = 0x16

AAAA = positive or negative number of increments to wait for until operation continues; here it depends on the used counting direction of the encoder if the given distance-value has to be positive or negative, when sign of the number and counting direction of the encoder do not fit to each other, the controller will halt at this position for a very long time

BBBB = unused, set to 0

EEEE = unused, set to 0

Insert a delay into the stream of data

This command adds a delay and lets the controller wait for the given time of ticks until the next command is executed. One tick is equal to 0,5 usec.

C = 0x18

AAAA = number of ticks to wait for

BBBB = unused, set to 0

EEEE = unused, set to 0

Switch LP8-Latch-output

Turns the LP8-Latch-output on or off.

C = 0x19

AAAA = turn Latch output on when equal to 1, turn it off when 0

BBBB = unused, set to 0

EEEE = unused, set to 0

Specify output for MIP-signal

Specify a single output pin of Digi I/O Extension Board to be used for "Mark in progress"-signal, this output pin will be HIGH as long as a marking operation is in progress.

C = 0x2A

AAAA = the number (not a bitpattern!) of the digital output pin to be used for MIP-signal (in range 0..7)

BBBB = unused, set to 0

EEEE = unused, set to 0

Halt/continue current marking operation

Stops the current marking operation on very next appearance of a jump or continue a previously halted operation.

C = 0x2F

AAAA = 1 to halt marking and 0 to continue a halted operation

BBBB = unused, set to 0

EEEE = unused, set to 0

Specify output for WET-signal

Specify a single output pin of Digi I/O Extension Board to be used for "Wait External Trigger"-signal, this output pin will be HIGH as controller is waiting for an external trigger.

C = 0x33

AAAA = the number (not a bitpattern!) of the digital output pin to be used for WET-signal (in range 0..7)

BBBB = unused, set to 0

EEEE = unused, set to 0

Set first row of 2x2 output matrix

Specify the elements m11 and m12 of a 2x2 output matrix which is applied to all coordinate values as soon as the second half is applied with command 0x41. This matrix can be used to scale, slant, rotate and mirror the input coordinates in respect to the output positions. For details please check out description of command 0x41 below

C=0x40

AAAA = the m11 part of the 2x2 matrix multiplied with 1000000

BBBB = the m12 part of the 2x2 matrix multiplied with 1000000

EEEE = unused, set to 0

Set second row of 2x2 output matrix

Specify the elements m21 and m22 of a 2x2 output matrix which is applied to all coordinate values together with the first row of matrix data which has to be set using command 0x40 in a preceding call. This matrix can be used to scale, slant, rotate and mirror the input coordinates in respect to the output positions. Assumed a matrix bases on an 4-elements array, it has following structure:

```
{m11, m12, m21, m22}
```

then these matrix values can be used and even combined with each other by multiplying them:

- rotation: {cos(angle), -sin(angle), sin(angle), cos(angle)}
- scaling: {factorX, 0.0, 0.0, factorY}
- slant X: {1.0, 1.0/tan(angle), 0.0, 1.0}
- slant Y: {1.0, 0.0, 1.0/tan(angle), 1.0}
- mirror X: {-1.0, 0.0, 0.0, 1.0}
- mirror Y: {1.0, 0.0, 0.0, -1.0}

C=0x41

AAAA = the m21 part of the 2x2 matrix multiplied with 1000000

BBBB = the m22 part of the 2x2 matrix multiplied with 1000000

EEEE = unused, set to 0

Download new firmware

Download a new firmware file to the controller and write it to the microSD-card so that it can be used after next reboot. The binary data of the new firmware have to be appended directly to this command. This command has to be used in a specific sequence in order to ensure the current firmware file is updated correctly:

- ensure the card is idle (state-flag SSSS is 0)
- send command 0x45 with length of firmware data and checksum
- send binary firmware data directly after this command
- wait until card state returns "active" (by repeatedly sending ping-commands), now in state flag SSSS bit 0x4000 (E170X\_CSTATE\_WRITING\_DATA) is set
- wait until card state returns "idle" again (by repeatedly sending ping-commands), the flag 0x4000 no longer should be set in state flag SSSS
- check if an error occurred: when flags 0x8000 (E170X\_CSTATE\_WRITING\_DATA\_ERROR) is set in state flag SSSS, downloading or writing or checksum calculation failed and the original file was not replaced; for debugging in such a case the command "cglog" can be called repeatedly until the related error text was found; when this error flag is set it can be reset only by using command 0x45 again
- reboot the controller
- check if the version of the firmware has changed

C = 0x45

AAAA = the length of the firmware file in bytes

BBBB = checksum for verification of the downloaded data, only when this checksum is correct, the old firmware file will be replaced; the checksum can be calculated using following function (C example code):

```
unsigned int crc32b(const char *buf, size_t len)
```

```

{
    int          k;
    unsigned int crc=0xFFFFFFFF;

    while (len--)
    {
        crc^=*buf++;
        for (k=0; k<8; k++)
            crc=crc&1 ? (crc>>1) ^ 0x82f63b78 : crc>>1;
    }
    return ~crc;
}

```

EEEE = specifies the file which has to be overwritten by the current data download:

- 0 - overwrite file 0:/version.txt when downloading of data was successful
- 1 - overwrite file 0:/e1702.fwi when downloading of data was successful
- 2 - overwrite file 0:/e1702.dat when downloading of data was successful
- 3 - overwrite file 0:/e1702.cfg when downloading of data was successful

#### Set Position Offset

Set a positive or negative offset which then applies to all following position commands submitted via command 0x00 or 0x01.

C = 0x4A

AAAA = x-position offset in range -33554432..33554432

BBBB = y-position offset in range -33554432..33554432

EEEE = z-position offset in range -33554432..33554432

#### Reset the board

This function performs a warm reboot of the hardware and restarts the firmware. Reboot is done immediately, means this command does not return anything but connection to the board will be interrupted as soon as it has been sent.

C = 0xFF

AAAA = unused, set to 0

BBBB = unused, set to 0

EEEE = unused, set to 0

## 9 Supported CNC G-Code Commands

Starting with firmware version 4 the E1702 supports G-codes sent to the controller via USB serial interface or Telnet. Such a data transfer has to be started with command “`cxnc`” (for details please refer to description above).

Starting with firmware version 4 the controller can also be configured to be in G-Code reception mode permanently by adding a parameter “`cxnc`” to the `e1702.cfg` configuration file.

When one of these direct control modes is active, a calling application can watch the execution state either via a digital output which is configured by using the configuration parameter `wetout`, or via a specific G-Code control protocol that is described in section 9.5 Control Protocol below.

To allow fast and efficient processing of a CNC file within E1702, some points have to be noticed. So in order to improve loading performance it is recommended to:

- not to have lots of leading or trailing spaces
- not to make use of large comments
- have exactly one space between code and related parameter

Beside of that it is mandatory to

- have a space or CR/LF between two different codes (so e.g. “`G21 G90`” is valid but “`G21G90`” will result in an error)
- have no space within a code or within a parameter of a code (so e.g. “`G0 X-0.5 Y.75 Z10`” is valid but “`G 0 X-0 .5 Y. 75 Z 10`” is not and will result in an error)
- use a dot as separator in floating point variables (so e.g. “`T1 F6000.0`” is valid but “`T1 F6000,0`” is not and will result in an error)

Following the G-Code commands are described which are supported.

### 9.1 General G-Code Characters

Following codes and identifiers are supported by E1702 G-Code interpreter:

| Code | Description  | Example   |
|------|--|---|
| %    | Marks the begin of a G-Code file, this code is optional and does not have any effect   |   |
| ;    | Begin of a comment, the remaining line is ignored; in order to improve loading speed of a G-Code file comments and spaces at the end of a line should be removed               | <code>G21 ; set unit to mm</code>                                   |
| ()   | Encapsulate a comment, all data within the brackets are ignored; in order to improve loading speed of a G-Code file comments and spaces at the end of a line should be removed | <code>G21 (set unit to mm) G90</code><br>(use absolute positioning) |
| G    | G-commands, please refer below for a description   | <code>G1 X25.75 Y31 Z0.25</code>                                    |
| M    | M-commands, please refer below for a description   | <code>M3</code>   |
| T    | T-commands, please refer below for a description   | <code>T1 F3000</code>   |

### 9.2 Supported “G”-codes

Following “G” codes and identifiers are supported by E1702 G-Code interpreter:

| Code | Description   | Example  |
|------|---|--|
| G0   | Jump to a specified position using predefined unit mm or inch and with maximal speed or – when set with command M704 – with the jump speed that was defined before. The position to jump to is specified by two or three parameters X, Y and Z. This movement is done with the laser turned off and by taking laser and scanner delays into account.  | G0 X0 Y0 Z0  |
| G1   | Move to a specified position using predefined unit mm or inch and with a default or – when set with command M704 – with the mark speed that was defined before. The position to move to is specified by two or three parameters X, Y and Z. This movement is done with the laser turned on and by taking laser and scanner delays into account.   | G1 X10 Y10.5 Z11.75                                  |
| G2   | <p>Adds a clockwise arc move with the laser turned on. An arc move starts at the current position and ends at the given XY coordinate, pivoting around a centre point offset given by the coordinates I and J or specified by the radius R. This command has two forms:</p> <p>IJ-form</p> <ul style="list-style-type: none"> <li>• I and J specify an X and Y offset, at least one of them is always required</li> <li>• mixing I or J with R will result in an undefined behaviour</li> </ul> <p>R-form</p> <ul style="list-style-type: none"> <li>• R specifies the radius, X and Y is mandatory</li> <li>• X or Y must be different from the current position</li> <li>• mixing I or J with R will result in an undefined behaviour</li> </ul> <p>Requires firmware version 20 or newer</p> | <p>G2 X12.5 Y30 I10 J10</p> <p>G2 X19 Y22.5 R 10</p> |
| G3   | <p>Same as G2 but performs counter-clockwise movements, for details please refer above.</p> <p>Requires firmware version 20 or newer</p>  | <p>G3 X12.5 Y30 I10 J10</p> <p>G3 X19 Y22.5 R 10</p> |
| G4   | When followed by a parameter „P“ execution is delayed by the given time (in unit seconds)   | G4 P0.002  |
| G17  | Select the XY plane for marking operations. This means, given jump or movement coordinates in X and Y directions are applied to X and Y plane, optional Z coordinate is applied to remaining Z direction.   | G17  |
| G18  | Select the ZX plane for marking operations. This means, given jump or movement coordinates in X and Y directions are applied to Z and X plane, optional Z coordinate is applied to remaining Y direction.   | G18  |
| G19  | Select the YZ plane for marking operations. This means, given jump or movement coordinates in X and Y directions are applied to Y and Z plane, optional Z coordinate is applied to remaining X direction.   | G19  |
| G20  | Set measurement unit to inch, means all positions handed over e.g. with G0 or G1 will be followed by coordinates in inch. In reality this has no effect for E1702 since calculation of marking positions is done based on the given working area which has to be defined with command M709  | G20  |

| Code | Description  | Example |
|------|--|---------|
| G21  | Set measurement unit to mm, means all positions handed over e.g. with G0 or G1 will be followed by coordinates in mm. In reality this has no effect for E1702 since calculation of marking positions is done based on the given working area which has to be defined with command M709     | G21     |
| G70  | Set measurement unit to inch, means all positions handed over e.g. with G0 or G1 will be followed by coordinates in inch. In reality this has no effect for E1702 since calculation of marking positions is done based on the given working area which has to be defined with command M709 | G70     |
| G71  | Set measurement unit to mm, means all positions handed over e.g. with G0 or G1 will be followed by coordinates in mm. In reality this has no effect for E1702 since calculation of marking positions is done based on the given working area which has to be defined with command M709     | G71     |
| G90  | Enable absolute positioning, means all positions handed over e.g. with G0 or G1 will be followed by absolute coordinates according to the used coordinate system.  | G90     |
| G91  | Enable relative positioning, means all positions handed over e.g. with G0 or G1 will be followed by coordinates that are relative to the previously used position in used coordinate system.   | G90     |

### 9.3 Supported “M”-codes

Following “M” codes and identifiers are supported by E1702 G-Code interpreter, here all codes in range 700..799 are specific to the E1702 and contain all laser-related parameters and values:

| Code | Description  | Example         |
|------|--|-----------------|
| M2   | End of program. When this code is found, parsing of the CNC file is stopped and all following codes are ignored  | M2              |
| M3   | Set laser on. This command does NOT turn on the laser but sets the internal state to „on“. This can be used to set e.g. the mark speed by a following command T1.  | M3              |
| M5   | Set laser off. This command does NOT turn on or off the laser but sets its internal state to „off“. This can be used to set e.g. the jump speed by a following command T1.   | M5              |
| M700 | Set the used laser type. This command is mandatory and has to be called prior to every laser-related command. As parameter it expects a <u>decimal</u> number which corresponds to the lasermode-types E170X_LASERMODE_XXX as described in section „10.1 E1702 Easy Interface Functions“               | M700 1073741831 |
| M701 | Set the frequency for the laser in unit Hz. This command is a place holder and has no effect when used with E1702. Instead of that, the frequency has to be set lasertype-dependent via pulse length parameter of commands M715 (stand-by frequency) and M718 (mark or continuously running frequency) | M701 25000      |

| Code | Description  | Example                 |
|------|--|-------------------------|
| M702 | Set the laser power in unit 1/1000%. This command has to be used only in case of specific lasermodes. Resulting from the mode the effect is different:<br>E170X_LASERMODE_MOPA – used in case of an IPG-laser, the power-value is latched out at LP8 laserport   | M702 75555              |
| M703 | Set laser-on-delay (at parameter A) and laser-off-delay (at parameter B) in unit usec.   | M703 A100 B200          |
| M704 | Set jump-speed (at parameter A) and mark-speed (at parameter B) in unit mm/min.<br>By default, when no value has been specified, a jump speed of 1000 mm/sec and a mark speed of 10 mm/sec is assumed.   | M704 A8936.592 B3000.00 |
| M705 | Set jump-delay (at parameter A), mark-delay (at parameter B) and in-polygon-delay (at parameter C) in unit usec.   | M705 A500 B200 C2500    |
| M707 | Set the working area left position (at parameter X), top position (at parameter Y) and depth position (at optional parameter Z) in unit specified with commands G70 or G71. Together with M709 this command specifies the valid working field, all positioning parameters handed over with e.g. G0 and G1 need to be located within this area.   | M707 X-50 Y50           |
| M709 | Set the working area width (at parameter X), height (at parameter Y) and depth (at optional parameter Z) in unit specified with commands G70 or G71. Together with M707 this command specifies the valid working field, all positioning parameters handed over with e.g. G0 and G1 need to be located within this area.<br>By default, when no value has been specified, a working area size of 100x100x100 mm is assumed. | M709 X-50 Y50           |
| M710 | IPG pulse length value in unit nsec. This command is for future use and currently does not have any effect.  | M710 10000              |
| M711 | Set wobble distance in X-direction (at parameter X), Y-direction (at parameter Y) in unit specified by commands G70 or G71 and wobble frequency (at parameter C) in unit Hz. When all values are set to 0, wobble marking is disabled completely.  | M711 X2.5 Y2.5 C10000   |
| M713 | Set first pulse killer value (FPK) for YAG laser types using unit usec   | M713 10000              |
| M715 | Set standby-frequency (at parameter A) in unit Hz and standby-pulsewidth (at parameter B) in unit nsec.  | M715 A50000 B1000       |
| M717 | Set waveform number for SPI laser types latched out at LP8 laser port.   | M717 17                 |
| M718 | Set laser frequency (at parameter A) in unit Hz and pulsewidth (at parameter B) in unit usec.  | M718 A50000 B10         |
| M719 | Switch main oscillator on (1) or off (0). This command can be used together with SPI or IPG laser types prior to starting a mark operation to turn MO on or afterwards to turn it off. Required delays to turn on the MO are handled by E1702 internally.  | M719 1                  |
| M720 | This command is valid for CNC-operations only, that are invoked by the command "cxcnc".<br>It flushes the currently collected CNC data and starts the related marking operation (if not already active).   |                         |

| Code | Description   | Example   |
|------|---|-----------|
| M721 | This command can be used to set custom default values for scanner movements. By default, X and Y axes are assumed to be centred within their working range and Z is assumed to be at the very bottom. At the very beginning, all movements with G0 or G1 commands will start at these positions causing a hard jump of the scanner when its default position is different. So using this command, an other default/starting position can be specified which fits to the default position of the scanner. This command has to be used after setting the working area scale value with M709, after setting the metric working area offset with M707 and prior the very first usage of G0/G1. This command requires firmware version 4 or newer. | M721 Z2.5 |

## 9.4 Supported “T”-codes

Following “T” codes and identifiers are supported by E1702 G-Code interpreter:

| Code | Description   | Example    |
|------|---|------------|
| T1   | Set jump or mark speed to be used with commands G0 and G1 in unit mm/min. Here it depends on a previous M-command if this value specifies the mark-speed (M3) or the jump speed (M5). | T1 F6000.0 |

## 9.5 Control Protocol

While the G-Codes, its syntax and meaning are standardised, the communication protocol that is used to evaluate the current state of the CNC-like operation, is not defined. Here several different control standards and protocols exist that are not compatible to each other. So this controller makes use of a very common, slim and easy to interpret control protocol: the one which is known from the GRBL free software. Due to the different type of controller, there are some changes which are described here.

Following commands can be sent in between a stream of G-code data (different to GRBL they all have to be completed with a CR/LF in order to let the client software transmit the command to the controller properly):

- ? - check the current state of processing. Here a string is returned which makes use of following syntax:

```
<STATE|WPos:x,y,z|Pn:0x00000000>
```

Here state can be “Idle” (when no marking operation is in progress), “Trig” when a marking process is active but the controller waiting for an external trigger signal at the ExtStart-input, “Hold” when a marking process is active but the execution was held by the “!” control command or “Run” when a marking operation is in progress;

WPos is an optional value which returns the current/last position which was emitted to the scanhead at the X, Y and Z channels (using format 0.00);

Pn is an optional value which returns the state of the digital inputs at the digital interface(s); this format is slightly different to the GRBL variant, here a hexadecimal number is given which represents the input pattern while GRBL lets one single character appear for each known input

- ! - halt the current marking operation at the next suitable position, means the next time when the laser is turned off regularly; when this control command is used, the marking state changes from “Run” to

## “Hold”

- ~ - continue a marking operation which was held with the “!” control command
- `cstat` - similar to the `cstat`-command as described at “8.2 Stand-Alone Control Commands”, this command returns the current marking state as textual representation making use of the syntax of the `cstat`-command as described above

# 10 Programming Interfaces

The e170x.dll / libe170x.so shared library provides an own programming interface that gives the possibility to access and control the E1702 scanner controller card.

## 10.1 E1702 Easy Interface Functions

These functions belong to the native programming interface of E1702 scanner card and should be used preferential in order to get access to all features and full performance of the scanner card. Header files and additional data required for using this interface can be found online in our public GIT-repository at <https://sourceforge.net/p/oapc/code/ci/master/tree/libe170x/>.

Functions of E1702 Easy Interface are either stream commands that are executed in the order they are called, or functions that are executed immediately.

The E1702 does NOT use the outdated concept of two or more lists that have to be completely managed and switched by the calling application. Here all stream commands simply are sent to the card without the need to provide some additional management information. Output of data is started only when `E170X_execute()` is called or when a card-internal threshold is exceeded. This card-internal triggered output of data can be held back only by calling function `E170X_set_trigger_point()` as very first so that marking starts only after an external trigger signal was detected by the card. In this case it is necessary to watch the buffer fill level of the card to avoid a buffer-overrun by calling function `E170X_get_free_space()`.

E1702 Easy Interface uses unit "bits" as base for all units and parameters. Since E1702 card internally uses 26 bits resolution for a better accuracy and to minimize round off errors, all calculation is done with these 26 bits. So the working area always has a size of 26 x 26 bits equal to 67108864 x 67108864. Independent from real resolution and output of hardware all calculations have to be done within this 26 bit range.

E1702 Easy Interface provides following general functions:

**unsigned char E170X\_set\_connection(const char \*address)**

This function has to be called as very first. It is used to specify the IP address where the card is accessible at (in case of Ethernet connection) or the serial interface (in case of USB connection, "COMx" for Windows and "/dev/ttyACMx" for Linux where "x" is the number of its interface). By default IP 192.168.2.254 is used. This is the only function that has to be called in case of both, when compatibility functions and when E1702 Easy Interface functions are used.

It returns a board instance number that has to be used with all following functions.

Please note: this function does only set the connection information, it does not yet open the connection to the controller! This happens on first call to `E170X_load_correction()`.

Parameters:

`address` - a char-array containing the IP in xxx.yyy.zzz.aaa notation or the name of the COM port to be used

Return: the board instance number or 0 in case of an error

**void E170X\_set\_password(const char n, const char \*ethPwd)**

Sets a password that is used for Ethernet connection of E1702 card. The same password has to be configured on E1702 configuration file e1702.cfg with parameter "passwd" to add an additional level of security to an Ethernet controlled card.

 PLEASE NOTE: usage of this password does NOT provide enough security to control the card via networks that are accessible by a larger audience, publicly or via Internet! Also when this password is set, the card always should operate in secured, separated networks only!

Every card and every connection should use an own, unique password that can consist of up to 48 characters containing numbers, lower- and uppercase letters and punctuation marks. Due to compatibility reasons no

language-specific special character should be used.

When connected via USB serial interface, this password is ignored. In this case no authentication is done.

Parameters:

`ethPwd` – the password to be used to authorise at an E1702 card. To reset a local password for connecting to a card that doesn't has a Ethernet password configured, hand over an empty string "" here

```
int E170X_load_correction(unsigned char n, const char* filename, unsigned char tableNum)
```

Loads a correction file to be used during vector data output. In case a previously loaded correction table has to be flushed and no other correction has to be used, parameter "filename" needs to be empty. This function has to be called for first time on initialisation and before any vector data are sent to the board. It is mandatory to call this function at least once since it establishes connection to E1702 card. So when no correction file has to be used, this function still has to be called but with an empty filename "".

This function supports different correction table file formats directly and without previous conversion:

- BeamConstruct .bco high resolution files
- Scanlab .ctb and .ct5 files
- SCAPS .ucf files
- Raylase .gcd files
- Rofin .fcr files
- CTI/GSI .xml files
- Sunny .txt 5x5 point correction files
- Han's .crt files

This is not a stream-command, means its data may be applied immediately and independent from current stream state.

Parameters:

`n` – the 1-based board instance number as returned by `E170X_set_connection()`

`filename` – the full path to the correction file to be loaded from file system, when "" is specified here, a previously used correction file is flushed and no/neutral correction is used as long as no other correction table is given

`tableNum` – the 0-based correction table number these data have to be loaded for; it is possible to download up to 16 different correction tables and to switch between them during operation using function `E170X_switch_correction()`

Return: `E170X_OK` or an `E170X_ERROR_` - return code in case of an error

```
void E170X_close(const unsigned char n)
```

Closes the connection to a card and releases all related resources. After this function was called, no more commands can be sent to the card until `E170X_set_connection()` and `E170X_load_correction()/n_load_correction_file()/load_correction_file()/ScSCIInitInterface()` is called again.

Parameters:

`n` – the 1-based board instance number as returned by `E170X_set_connection()`

```
int E170X_switch_correction(unsigned char n, unsigned char tableNum)
```

Switches between up to 16 correction tables on the fly. When a table-number is given where no file was downloaded before using function `E170X_load_correction()`, no correction is performed on all following vector data.

This is a stream-command, means the new correction is applied to vector data sent to the card after this command but NOT to already sent but not yet processed data. Thus on-the-fly switching between correction tables is possible.

**Parameters:**

`n` – the 1-based board instance number as returned by `E170X_set_connection()`  
`tableNum` – the 0-based table number of the correction that has to be used for all following vector data

**Return:** `E170X_OK` or an `E170X_ERROR_`-return code in case of an error

```
int E170X_set_debug_logfile(const unsigned char n,const char *path,const unsigned char flags)
```

This function can be used during development to check an own application regarding called commands and their parameters. It lets libe1702 write all function calls into a logfile so that it is possible to evaluate the real order of commands.

**Parameters:**

`n` – the 1-based board instance number as returned by `E170X_set_connection()`  
`path` – full path to the file which has to be used as debug log file  
`flags` – a bunch of OR-concatenated flags which specify what function calls have to be written into or filtered from the log output; when `0x00` is specified here, the log file is kept quite small. When `0x01` is set, all motion-related function calls are added too, when `0x02` is set, all calls which check the state of the card are added to the log file.

**Return:** `E170X_OK` or an `E170X_ERROR_`-return code in case of an error

```
int E170X_set_xy_correction(const unsigned char n,const unsigned int flags,const double gainX, const double gainY,const double rot,const int offsetX,const int offsetY,const double slantX, const double slantY)
```

Sets size correction factor and offset for X and Y direction of working area as well as a rotation. With this command a matrix set with `E170X_set_matrix()` will be overwritten.

This is a stream-command, means its parameters are applied at a point in stream that is relative to the other stream commands and changed values apply only to these vector data and coordinates, which are sent after calling this function.

**Parameters:**

`n` – the 1-based board instance number as returned by `E170X_set_connection()`  
`flags` – following flags can be set:

- `E170X_COMMAND_FLAG_XYCORR_MIRRORX` – the output will be mirrored in X-direction
- `E170X_COMMAND_FLAG_XYCORR_MIRRORY` – the output will be mirrored in Y-direction

`gainX` – scale factor in x-direction, 1.0 means no scaling  
`gainY` – scale factor in y-direction, 1.0 means no scaling  
`rot` – rotation of whole working area in unit degrees  
`offsetX` – offset in x-direction in unit bits, 0 means no offset  
`offsetY` – offset in y-direction in unit bits, 0 means no offset  
`slantX` – trapezoidal correction along X-axis in range -45..45°  
`slantY` – trapezoidal correction along Y-axis in range -45..45°

**Return:** `E170X_OK` or an `E170X_ERROR_`-return code in case of an error

```
int E170X_set_z_correction(const unsigned char n,const unsigned int h,const double xy_to_z_ratio,const int res1)
```

Set additional Z correction parameter. This function may be used in cases where third axis is used excessively and with a large Z working range, it has no effect when E1702S scanner card is used since it operates in 2D mode only. Otherwise, in real 3D modes, additional deviation occurs when no F-Theta lens is used caused by the fact that the beam is always sent from the centre

of the scanhead – which causes some kind of projection resulting in larger or smaller X and Y positions depending on the real Z height.

This is a stream-command, means its parameters are applied at a point in stream that is relative to the other stream commands and changed values apply only to these vector data and coordinates, which are sent after calling this function.

Parameters:

`n` – the 1-based board instance number as returned by `E170X_set_connection()`

`h` – the vertical height from last mirror of the scanhead to the working area (Z-position 0 of working area) in unit bits

`xy_to_z_ratio` – factor specifying the ratio between maximal horizontal working area size and maximal vertical movement size. As an example: when the working area has a size of 100 x 100 mm and the Z-axis has a maximum movement range of -20 mm .. 20 mm, the ratio to be set is 2,5 (100 mm horizontal divided by 40 mm vertical)

`res1` – reserved for future use, set to 0

For more details please refer to the image below:

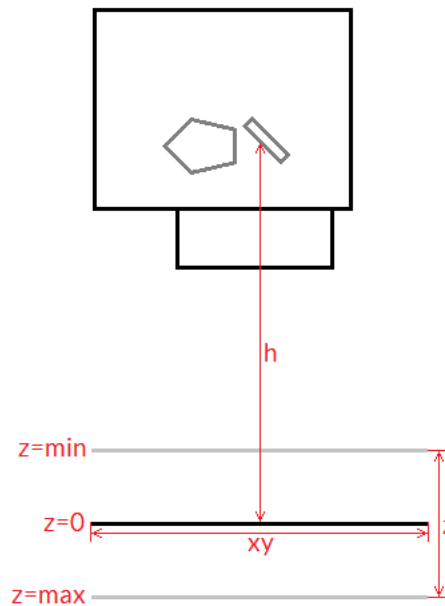

Here “h” is the height from the position where the beam hits the last mirror to the position of the working area at z=0 position (in unit bits). “xy” is the width of the working area to be used together with the “z” range from “z=min” to “z=max” to calculate the `xy_to_z_ratio`. All working area parameters like its width “xy” and the “z”-range are expected to be the theoretical maximum of the full range, not the – possibly smaller – range used in a specific setup.

Return: `E170X_OK` or an `E170X_ERROR_`-return code in case of an error

**int E170X\_set\_speeds(unsigned char n, double jumpspeed, double markspeed)**

Set scanner speed values to be used for all following vector data and until not replaced by other speed values.

This is a stream-command, means its parameters are applied at a point in stream that is relative to the other stream commands and changed values apply only to these vector data and coordinates, which are sent after calling this function.

Parameters:

`n` – the 1-based board instance number as returned by `E170X_set_connection()`

`jumpspeed` – scanner movement speed during jumps (movements when laser is off) in unit bits/msec and range 1..4294960000

markspeed – scanner speed during mark (movements when laser is on) in unit bits/msec and range 1..4294960000

Return: E170X\_OK or an E170X\_ERROR\_-return code in case of an error

```
int E170X_set_overspeed(const unsigned char n,const unsigned int flags,const double scannerLag,const double jumpFactor,const double reserved);
```

Turns on the overspeed function of the controller card which tries to move the scanhead with a multiple of its nominal speed without damaging the marking result by massive distortions. This function call can be used to enable and configure or to disable the overspeed-feature. Depending on the type of marking data this function can save nameable amounts of marking time. It can be used with any kind of scanhead which meet the following requirements:

- hardware is a galvo-driven scanhead
- is does not contain an internal speed limit that suppresses all speeds beyond an artificial limit

From technical point of view as soon as the overspeed function is enabled, all vector data are analysed by the controller card. When vectors are found which are suitable to be driven with overspeed, specific acceleration and deceleration ramps are done with these vectors to ensure the marking result itself is not distorted. Next these vectors are driven with a multiple of its normal speed. Vectors which are not suitable to be used with the overspeed function are left untouched, there neither any speed ramping is done nor is the nominal speed changed.

Parameters:

*n* – the 1-based board instance number as returned by `E170X_set_connection()`

*flags* – a set of operational flags that specify how the function has to be used, currently only

`E170X_COMMAND_FLAG_STREAM` is allowed

*scannerLag* – the lag (“tracking error”) of the scanner in unit msec; this value is predefined by the hardware of the scanhead and should be available from its technical data; when this value is equal or less than 0.0, the overspeed-function is turned off

*jumpFactor* – the factor the nominal jump speed (as set via function `E170X_set_speeds()`) is allowed to be exceeded during overspeed-drives; when this value is equal or less than 1.0, the overspeed-function is turned off

*reserved* – reserved for future use, has to be set to 0

Return: E170X\_OK or an E170X\_ERROR\_-return code in case of an error

```
int E170X_set_laser_delays(const unsigned char n,double ondelay,double offdelay)
```

Set laser delay values to be used for all following vector data and until not replaced by other delay values.

This is a stream-command, means its parameters are applied at a point in stream that is relative to the other stream commands and changed values apply only to these vector data and coordinates, which are sent after calling this function.

Parameters:

*n* – the 1-based board instance number as returned by `E170X_set_connection()`

*ondelay* – laser on delay in unit microseconds, can be a negative or a positive value

*offdelay* – laser off delay in unit microseconds, must be a positive value

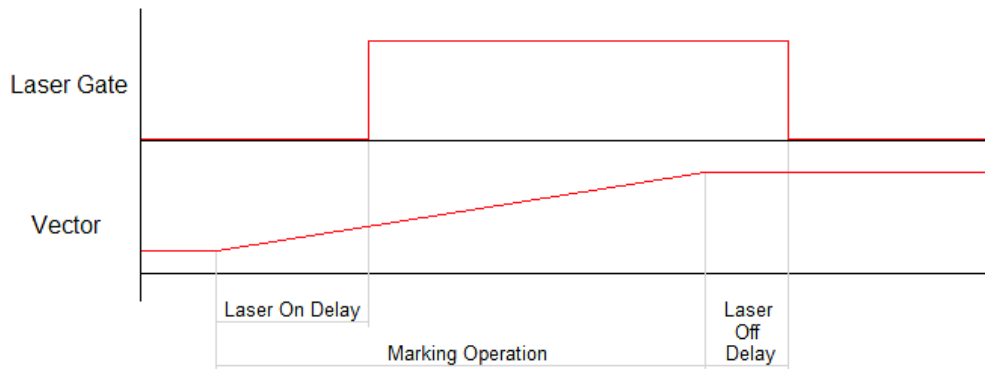

Return: E170X\_OK or an E170X\_ERROR\_-return code in case of an error

**int E170X\_set\_scanner\_delays(const unsigned char n, const unsigned int flags, const double jumpdelay, const double markdelay, const double polydelay)**

Set scanner delays in unit microseconds. Smallest possible value and resolution is 0.5 microseconds. This is a stream-command, means its parameters are applied at a point in stream that is relative to the other stream commands. So values set here apply only to these vector data that are sent after this command.

Parameters:

*n* - the 1-based board instance number as returned by `E170X_set_connection()`

*flags* - here some flags can be set which add some further functional specifications and features to this function. At the moment following flags are supported and can be OR-concatenated with each other:

- `E170X_COMMAND_FLAG_SCANNER_VAR_POLYDELAY` - when this flag is set, the value set via *polydelay* is not applied statically to every point within a polygon, but it is set dynamically depending on the angle between two lines; no angle (a straight line) results in no delay while a 180 degree angle results in a full delay as set by value *polydelay*

*jumpdelay* - the jump delay value in unit microseconds

*markdelay* - the mark delay value in unit microseconds

*polydelay* - the in-polygon delay value in unit microseconds

Return: E170X\_OK or an E170X\_ERROR\_-return code in case of an error

**int E170X\_set\_laser\_mode(unsigned char n, unsigned int mode)**

Sets the laser mode to be used for all following operations, this value influences the signals emitted at the connectors of the card. This function has to be called prior to setting any other laser parameters (like frequency, standby-frequency, power).

This is a stream-command, means its parameters are applied at a point in stream that is relative to the other stream commands.

Parameters:

*n* - the 1-based board instance number as returned by `E170X_set_connection()`

*mode* - the laser mode, here one of the following values is possible:

- `E170X_LASERMODE_CO2` - for controlling CO2 lasers, this mode supports stand-by frequency at LaserA output (to be set with function `E170X_set_standby()`) and PWM-modulated frequencies during marking and for power control (to be set with function `E170X_set_laser_timing()`)
- `E170X_LASERMODE_YAG1` - for controlling YAG lasers, this mode supports stand-by and Q-Switch frequency at LaserA output (to be set with function `E170X_set_standby()`) and a first pulse killer signal at output LaserB that is issued on beginning of a mark together with the Q-Switch frequency (to be set with function `E170X_set_fpk()`):

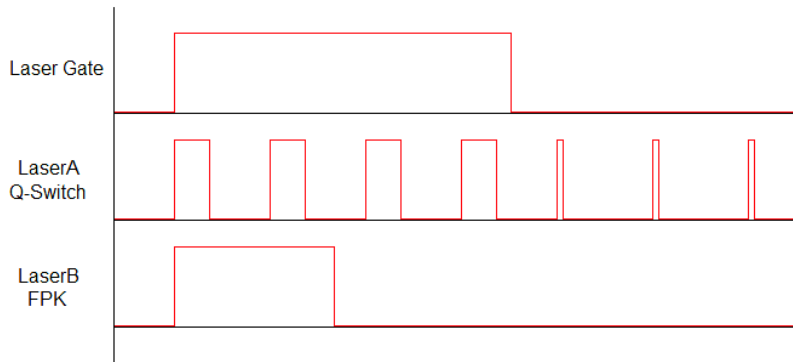

Here Q-Switch signal is started together with laser gate and FPK pulse. At end of mark when laser gate is turned off stand-by frequency is emitted at LaserA.

- `E170X_LASERMODE_YAG2` - for controlling YAG lasers, this mode supports stand-by and Q-Switch frequency at LaserA output (to be set with function `E170X_set_standby()`) and a first pulse killer signal at output LaserB that is issued on beginning followed by Q-Switch frequency that starts when FPK pulse has finished:

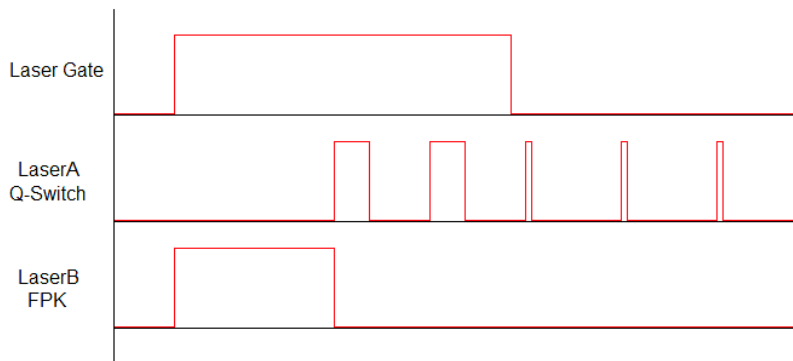

Here FPK and laser gate are started together. Q-Switch signal is started at end of FPK pulse. At end of mark when laser gate is turned off, stand-by frequency and pulse-width is emitted at LaserA instead of Q-Switch frequency.

- `E170X_LASERMODE_YAG3` - for controlling YAG lasers, this mode supports stand-by and Q-Switch frequency at LaserA output (to be set with function `E170X_set_standby()`) and a first pulse killer signal at output LaserB that is issued on beginning followed by Q-Switch frequency that starts after a freely configurable time period "yag3QTime":

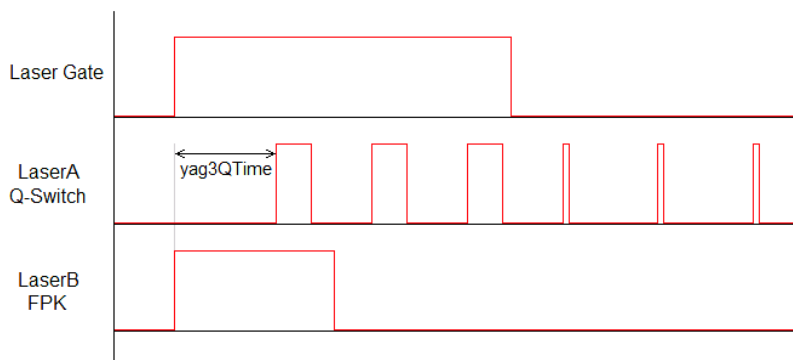

Here FPK and laser gate are started together. Q-Switch signal is started after yag3QTime has elapsed according to the beginning of FPK pulse. This time value can be set using function `E170X_set_fpk()`. At end of mark when laser gate is turned off, stand-by frequency and pulse-width is emitted at LaserA instead of Q-Switch frequency.

- `E170X_LASERMODE_CRF` - for controlling lasers that require a continuously running frequency (like fiber-lasers), this frequency is emitted at LaserA output and can be set and changed by calling function `E170X_set_standby()`.
- `E170X_LASERMODE_DFREQ` - for controlling special lasers that require two frequencies, the second, continuously running frequency is emitted at LaserB output and can be set with function `E170X_set_laserb()`

- `E170X_LASERMODE_MOPA` – for fiber lasers which are driven by a main oscillator and power amplifier and that are power-controlled via LP8 digital port and latch bit

Return: `E170X_OK` or an `E170X_ERROR_`-return code in case of an error

```
int E170X_set_laser(const unsigned char n,const unsigned int flags,const char on)
```

This function switches the laser on or off independent from any mark or jump commands and independent from many other, vector-data related timing.

Parameters:

`n` – the 1-based board instance number as returned by `E170X_set_connection()`

`flags` – handling flags specifying the behaviour of this command, `E170X_COMMAND_FLAG_STREAM` to use it as stream command, `E170X_COMMAND_FLAG_DIRECT` to execute it immediately and independent on current stream and execution state; in case `E170X_COMMAND_FLAG_STREAM` is used, please ensure this function call is followed by other stream commands, elsewhere the laser is turned off for security reasons as soon as no more data are available to process in order not to let the laser fire while the card is waiting

`on` – set to 1 to turn the laser on or to 0 to turn it off

Return: `E170X_OK` or an `E170X_ERROR_`-return code in case of an error

```
int E170X_set_wobble(const unsigned char n,unsigned int x,unsigned int y,double freq)
```

This function gives the possibility to not to let the laser beam follow the given path directly but to rotate around the specified path and lasers current position. Depending on chosen wobble-parameters and marking speed, this results either in a thick or a sinusoidal line. This call sets wobble parameters to be used for all following vector data and until not replaced by other wobble values or by 0 which disables wobble mode. This is a stream-command, means its parameters are applied at a point in stream that is relative to the other stream commands.

Parameters:

`n` – the 1-based board instance number as returned by `E170X_set_connection()`

`x` – wobble amplitude in x direction in units bits and range 1..10000000

`y` – wobble amplitude in y direction in units bits and range 1..10000000

`freq` – wobble frequency in Hz in range 1..25000

Return: `E170X_OK` or an `E170X_ERROR_`-return code in case of an error

```
int E170X_jump_abs(const unsigned char n,int x,int y,int z)
```

Perform a jump (movement with laser turned off) to the given position. This causes a galvo movement from current position to the one specified by this functions parameters using the jump speed and taking the jump delay into account:

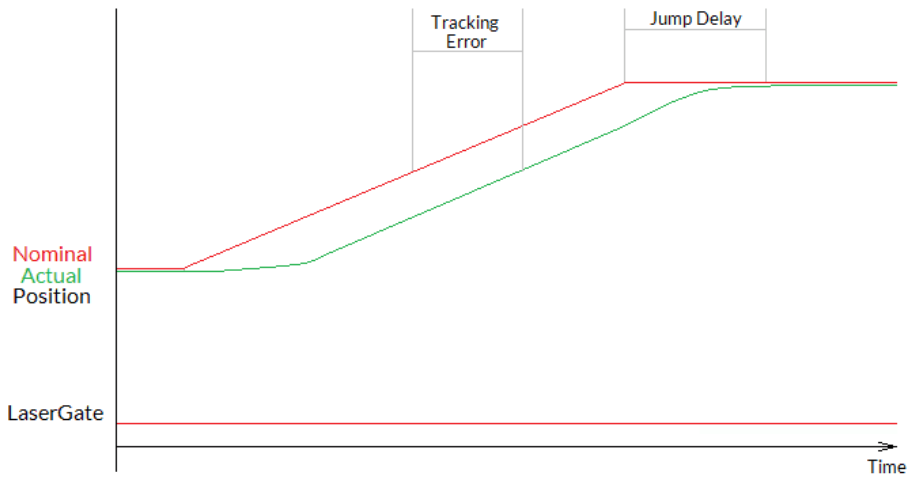

When laser was turned on before this function is called, laser is turned off at the beginning with a delay specified by laser off delay (please refer to description of E170X\_mark\_abs() for a diagram showing laser off delay too).

This is a stream-command, means it is executed at a point in stream that is relative to the other stream commands.

Parameters:

n – the 1-based board instance number as returned by E170X\_set\_connection()

x – the x-coordinate in unit bits the scanner has to jump to

y – the y-coordinate in unit bits the scanner has to jump to

z – the z-coordinate in unit bits the scanner has to jump to (not available with E1702S, requires a scanner-hardware that is equipped with Z- channel)

Return: E170X\_OK or an E170X\_ERROR\_-return code in case of an error

**int E170X\_mark\_abs(const unsigned char n,int x,int y,int z)**

Perform a mark (movement with laser turned on) to the given position. This causes a galvo movement from current position to the one specified by this functions parameters using the mark speed and taking the mark delay into account. When laser was turned off before this function is called, laser is turned on at the beginning with a delay specified by laser on delay:

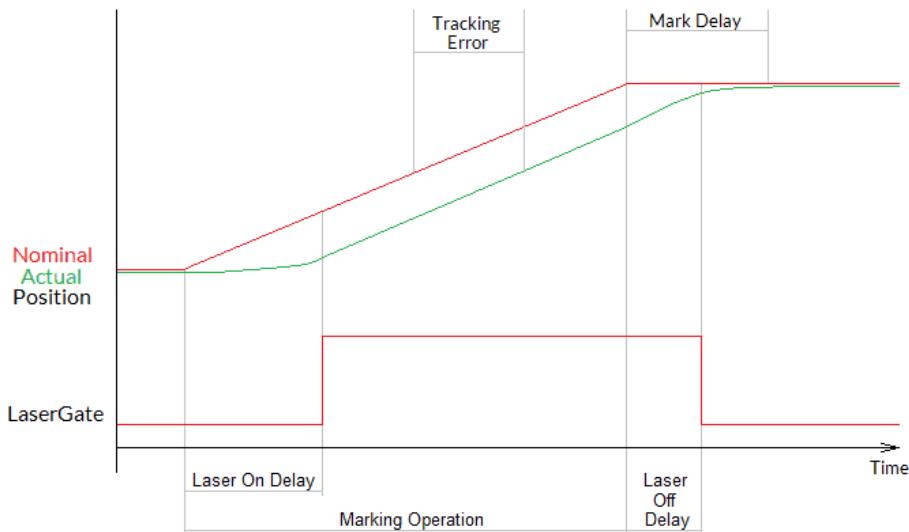

This is a stream-command, means it is executed at a point in stream that is relative to the other stream commands.

Parameters:

*n* – the 1-based board instance number as returned by `E170X_set_connection()`

*x* – the x-coordinate in unit bits the scanner has to move to

*y* – the y-coordinate in unit bits the scanner has to move to

*z* – the z-coordinate in unit bits the scanner has to move to (not available with E1702S, requires a scanner-hardware that is equipped with Z- channel)

Return: `E170X_OK` or an `E170X_ERROR_`-return code in case of an error

```
int E170X_get_pos(const unsigned char n,int *x,int *y,int *z)
```

This function returns the last position of the scanner:

- when an XY3-100 scanhead is connected, that provides its actual position, these values are returned
- when no such scanhead is connected, the last nominal position sent to the head are returned

The function needs the controller to be in idle-mode, means no marking operation is allowed to run in order to get the position information.

Please note: when a correction file is set, and/or a matrix is set and/or an offset is set and/or any other function is used which modifies the position data, the coordinates returned here are **not** the values which have been sent with the last call to `E170X_jump_abs()` or `E170X_mark_abs()` or `E170X_set_pos()` as they have been processed and modified by these correction functions. So while the jump/mark functions set position data according to the desired coordinate system, the values returned by `E170X_get_abs()` are the real-world coordinates at the hardware.

Return: `E170X_OK` or an `E170X_ERROR_`-return code in case of an error

```
int E170X_set_pos(const unsigned char n,int x,int y,int z,unsigned char laserOn)
```

Perform a raw, immediate movement to the given position.

 **HANDLE WITH CARE!** This function causes galvo movement to the given position immediately, without respect to any mark or jump speed values, without micro-vectorisation or intermediate steps! This means it can result in a very heavy movement for the galvos and in worst case it may cause some damage! Since the resulting movement speed may be way too high for the used galvos, they may overshoot and need some time until the desired position is reached. So this function is mainly intended to be used for very small position changes in respect to the galvos current position.

This is a stream-command, means it is executed at a point in stream that is relative to the other stream commands.

Parameters:

*n* – the 1-based board instance number as returned by `E170X_set_connection()`

*x* – the x-coordinate in unit bits the scanner has to jump to

*y* – the y-coordinate in unit bits the scanner has to jump to

*z* – the z-coordinate in unit bits the scanner has to jump to (not available with E1702S, requires a scanner-hardware that is equipped with Z- channel)

*laserOn* – specifies if the movement has to be done with laser turned on (1) or off (0)

Return: `E170X_OK` or an `E170X_ERROR_`-return code in case of an error

```
int E170X_set_pixelmode(const unsigned char n,const unsigned int mode,const double powerThres,const unsigned int res)
```

Set the operational mode for `E170X_mark_pixelline()`. This function influences the behaviour when marking a pixel line. This is a stream-command, means its parameters are applied at a point in stream that is relative to the other stream commands.

Parameters:

*n* – the 1-based board instance number as returned by `E170X_set_connection()`

mode – pixel marking mode, this parameter can be set to:

- 0 – default mode, while marking a pixel line the controller tries to perform jumps when power is below of the given threshold `powerThres` to save marking time
- `E170X_PIXELMODE_NO_JUMPS` – no jumps are performed, the given power threshold is ignored and the full pixel line is done with marking speed; this mode is slower but can result in more accurate and more exact images
- `E170X_PIXELMODE_JUMP_N_SHOOT` – marking of the line is no longer done with a continuous movement but with a sequence “jump to position → shoot → jump to next position → shoot → jump to next position → shoot...”; here the shoot-time is equal to the laser-off-delay minus laser-on-delay as set with function `E170X_set_laser_delays()`
- `E170X_PIXELMODE_HW_POWER_CONTROL` – when this flag is set, the controller card takes care about setting the power for the pixels. This works only when a laser mode is chosen where the scanner card supports native power control. When this flag is set, a power-callback, handed over together with a call to `E170X_mark_pixelline()` is ignored.
- `E170X_PIXELMODE_GATE_POWER_CONTROL` – this is a special bitmap marking mode where no real power control is supported. When this flag is set, the LaserGate output is toggled depending on the required output power. Since this output supports only states LOW and HIGH, this bitmap marking mode results in black and white images only
- `E170X_PIXELMODE_JUMP_LEAVE_POWER` – during bitmap marking, when no flag `E170X_PIXELMODE_NO_JUMPS` is set, below of a specific power threshold a jump is performed. By default, prior to such a jump, the laser power is set to 0 to handle faultily lasers that have spurious emissions even when LaserGate is at LOW. For laser types, which do not suffer from such emissions, this flag can be set. It leaves the last power value active also during jumps, which saves some marking time. So this flag can be used for speed-optimising bitmap-marking.

`powerThres` – this value is used only in default mode, when the marking power for some pixels is below of the given value (in unit percent), a jump is performed to save marking time, during this jump the laser is off and no marking is done

`res` – reserved, set always to 0

Return: `E170X_OK` or an `E170X_ERROR_`-return code in case of an error

```
int E170X_mark_pixelline(const unsigned char n,int x,int y,int z,int  
pixWidth,int pixHeight,int pixDepth,unsigned int pixNum,double  
*pixels,E170X_power_callback power_callback,void *userData)
```

This function can be used to mark a single line of a bitmap image. Here horizontal, vertical and even 3D bitmap lines (going into depth) can be marked. Direction and orientation of the line to be marked can be chosen freely. A full image can be created by concatenating several lines. Power control during marking of such a bitmap line is not limited to some specific power outputs, it can be fully customised via a callback function.

Parameters:

`n` – the 1-based board instance number as returned by `E170X_set_connection()`

`x`, `y`, `z` – the starting coordinates of the line in unit bits, an output on Z-axis is not available when E1702S is used

`pixWidth` – the width of a single pixel (in unit bits), when this is set to a value greater or smaller than 0 while all the others are equal 0, a horizontal line is drawn; the sign of the value specifies the marking direction

`pixHeight` – the height of a single pixel (in unit bits), when this is set to a value greater or smaller than 0 while all the others are equal 0, a vertical line is drawn; the sign of the value specifies the marking direction

`pixDepth` – the depth of a single pixel (in unit bits, requires a 3D-capable scanhead, not available when E1702S is used), when this is set to a value greater or smaller than 0 while all the others are equal 0, line goes into depth; the sign of the value specifies the marking direction

`pixNum` – the number of pixel data contained in the array of intensity values handed over with the following parameter

`pixels` – an array of double-values with a length equal the number of pixels specified with `pixNum` and with an allowed range of 0.0..100.0 specifying the intensity; every entry of this array is equal to one pixel of the

bitmap, so a greyscale-pixel line with brightness values in range 0..255 has to be converted to values in range 0.0..100.0

`power_callback` - this is a callback function of type

```
int (*E170X_power_callback)(unsigned char n, double power, void *userData)
```

which is used to set the power for every pixel. These `E170X_`-functions have to be called that belong to the used laser type and set the power values according to its hardware capabilities. Within the power callback function only stream commands are allowed to be called. It is not possible to use external devices that are not synchronous to E1702 command stream. The power callback has to return with `E170X_OK` when setting of power was successful. In case of an error the appropriate error code has to be returned, the pixel marking function will be cancelled in such a case too and does not finish marking of the line. Parameter `n` is the 1-based board instance number specifying the board the power has to be changed for, `power` is the power to be set in unit percent and `userData` are some free to use, custom data that can be handed over on call to `E170X_mark_pixelline()`.

`userData` - here some custom data can be handed over which are forwarded on and handed over at every call of the power-callback

**Return:** `E170X_OK` or an `E170X_ERROR_`-return code in case of an error

```
int E170X_set_matrix(const unsigned char n, const unsigned int flags, const double m11, const double m12, const double m21, const double m22)
```

Specify a 2x2 matrix that contains scaling and rotation corrections for the output. When a given matrix element parameter has a value smaller or equal -10000000 it is ignored and the previous/default value is kept at this position in matrix. With this command any correction set with `E170X_set_xy_correction2()` will be overwritten.

This is a stream-command, means its parameters are applied at a point in stream that is relative to the other stream commands.

**Parameters:**

`n` - the 1-based board instance number as returned by `E170X_set_connection()`

`flags` - reserved for future use, set to 0 for compatibility

`m11` - first matrix element in first row

`m12` - second matrix element in first row

`m21` - first matrix element in second row

`m22` - second matrix element in second row

**Return:** `E170X_OK` or an `E170X_ERROR_`-return code in case of an error

```
int E170X_set_trigger_point(const unsigned char n)
```

Specifies a point in data stream where execution has to stop until an external trigger signal (mark start) or a manual release of this trigger point is detected. This expects a rising edge on ExtStart input or calling of function `E170X_release_trigger_point()`.

This is a stream-command, means it is executed at a point in stream that is relative to the other stream commands.

**Parameters:**

`n` - the 1-based board instance number as returned by `E170X_set_connection()`

**Return:** `E170X_OK` or an `E170X_ERROR_`-return code in case of an error

```
int E170X_release_trigger_point(const unsigned char n)
```

This function should be called only when a call to `E170X_set_trigger_point()` was done before. It acts like an external trigger signal, releases the waiting condition and lets the controller start processing. So this function provides some kind of software-simulated external start-signal. ATTENTION: this command will not arrive at the controller when there is no more space left on it, means when all controller-internal buffers are filled. So after a call to `E170X_set_trigger_point()` and during sending of commands and data to the controller, application has to ensure there is some space left in controller's buffers. This can be done by calling `E170X_get_free_space()` with flag `E170X_FREE_SPACE_PRIMARY` for checking the available space in primary buffer. It is recommended to leave space for at least 10000 elements in primary buffer in order to let a call to `E170X_release_trigger_point()` work properly. When the buffers already have been filled completely, this function will no longer work and marking can be started only by applying the ExtStart hardware signal. This is not a stream-command, it is applied to controller immediately.

Parameters:

`n` - the 1-based board instance number as returned by `E170X_set_connection()`

Return: `E170X_OK` or an `E170X_ERROR_`-return code in case of an error

```
int E170X_set_sync(const unsigned char n,const unsigned int flags,const unsigned int value)
```

This function sends a synchronisation `value` to the controller. As soon as marking reaches the related position in stream, the value returned by function `E170X_get_sync()` changes to the value given here.

This command delays execution of the data by 0,5 usec, so it should not be used excessively. A value of `0xFFFFFFFF` disables this function.

Parameters:

`n` - the 1-based board instance number as returned by `E170X_set_connection()`

`flags` - currently unused, set to 0 for future compatibility

`value` - the value to be used as sync-identifier, here on every call a different value should be handed over in order to differentiate what is returned by `E170X_get_sync()`.

Return: `E170X_OK` or an `E170X_ERROR_`-return code in case of an error

```
unsigned int E170X_get_sync(const unsigned char n)
```

Returns a sync-identifier as set by `E170X_set_sync()` as soon as the related position in stream was reached.

Parameters:

`n` - the 1-based board instance number as returned by `E170X_set_connection()`

Return: the last sync-identifier which was identified and processed in stream of commands or `0xFFFFFFFF` when function is not used/turned off

```
int E170X_execute(const unsigned char n,const unsigned int flags)
```

Starts execution of all previously sent commands in case card is not already outputting these data. This function should be called typically once as soon as all vector data have been sent to the controller. It should be called in every sequence of commands, even when the controller is already marking to terminate the sequence of vectors which have been submitted. This call does not necessarily start the marking operation as the controller is free to decide to do this at an earlier point in time but it ensures a proper transmission of all data from control-PC to the controller. To exactly define when marking has to start, function `E170X_set_trigger_point()` should be used.

When parameter `flags` is set to 0, the function works asynchronously, means after flushing the marking data it returns immediately. In this case, the calling application has to check for the marking states “marking” and “idle” to find out if marking is completed (by using function `E170X_get_card_state()`).

When parameter `flags` is set to `E170X_COMMAND_FLAG_SYNC`, the function blocks, until marking has completed or has been stopped. In this case no further calls to `E170X_get_card_state()` are necessary, as the card state can be assumed to be “idle” when the function returns.

In general and independent from this function, marking is finished only when STOP (ExtStop signal input or `E170X_stop_execution()`) is invoked or when the internal buffer is empty. When internal buffer runs empty because subsequent data are not sent fast enough, an additional call to `E170X_execute()` is necessary in order to output the remaining data.

This is not a stream command since it controls the already sent stream of commands.

Parameters:

`n` - the 1-based board instance number as returned by `E170X_set_connection()`

Return: `E170X_OK` or an `E170X_ERROR_`-return code in case of an error

**int E170X\_stop\_execution(const unsigned char n)**

Stops the currently running execution as fast as possible and drops all marking data that still may be queued. Calling this function also would drop all laser and scanner parameters that are already sent but not yet processed. Thus after calling this function it may be necessary to set scanner and laser parameters again in order to ensure they are used for following operations.

This is not a stream command since it controls the current stream of commands.

**PLEASE NOTE:** this function should not be called on the off-chance “to be sure nothing is running”. The command works asynchronously and causes a state-change which can have some unwanted side-effects when it is used without a specific reason. So calling the function should be done only when the controller is really in state marking/running, and after calling it, no other functions have to be used until the state (`E170X_get_card_state()`) has changed back to idle. As the stop is done as fast as possible, the point, at what the stream is stopped, is undefined. Means any function that has been called between the last call to `E170X_execute()` and `E170X_stop_execution()` may not have an effect and probably needs to be repeated.

Parameters:

`n` - the 1-based board instance number as returned by `E170X_set_connection()`

Return: `E170X_OK` or an `E170X_ERROR_`-return code in case of an error

**int E170X\_halt\_execution(const unsigned char n, const unsigned char halt)**

Halts or continues the processing and output of marking data. On `halt=1` marking is stopped next time the laser is off. Different to a full stop no vector data are flushed. On continue (`halt=0`) controller continues processing at the point where halt occurred. When marking is stopped with `E170X_stop_execution()` the halt-condition is cleared too, means on next transmission of new marking data they are processed without the need to explicitly continue last operation.

Parameters:

`n` - the 1-based board instance number as returned by `E170X_set_connection()`

`halt` - 1 to halt operation next time the laser is off, 0 to continue a previously halted operation

Return: `E170X_OK` or an `E170X_ERROR_`-return code in case of an error

**unsigned int E170X\_get\_startstop\_state(const unsigned char n)**

This function returns a bit pattern that informs about state of the start and stop input pins.

This is not a stream command since it returns the current state immediately. Here “current state” means the last known state. When the state changes during this call, it may be possible the previous, no longer actual state is given back since transmission of data from controller to host is done asynchronously and independent from a call to this function.

Parameters:

`n` – the 1-based board instance number as returned by `E170X_set_connection()`

Return: a bit pattern specifying the current state:

- bit 0 and 1 (0x00000003) specify if the start input was set after last call of this function, when these bits are set, a rising edge has been detected at this input; calling this function resets the internal state of these bits, means when it is called again and when no new rising edge has been detected meanwhile, these bits will be 0
- bit 2 and 3 (0x0000000C) specify if the stop input was set after last call of this function, when they are set, a rising edge has been detected at this input; calling this function resets the internal state of these bits, means when it is called again and when no new rising edge has been detected at top input meanwhile, these bits will be low
- bit 12 (0x00001000) this bit signals the start input is low, as long as this bit is set no start input signal is detected

**`int E170X_get_card_state(const unsigned char n, unsigned int *value)`**

This function returns a bit pattern that informs about cards current operational state. Here “current state” means the last known state. When the state changes during this call, it may be possible the previous, no longer actual state is given back since transmission of data from controller to host is done asynchronously and independent from a call to this function.

The card-states are enqueued internally in order to not to lose a “busy”-state which may be available for a very short time only in case of very small and fast marking cycles. So every state change caused by the calling application results in on state change returned by this function. This means for every marking cycle the application has to wait for two state changes: first wait until this function signals “busy”

(`E170X_CSTATE_PROCESSING|E170X_CSTATE_MARKING`) next wait until this function signals “ready” (0).

During transfer of vector data and scanner/laser parameters this function should be called as rarely as possible: every call of `E170X_get_card_state()` performs a full cycle of transmission and receiving of data to and from the controller. Dependent on the current transmission state this may result in submission of a small block of data which does not uses the full available bandwidth. On excessive use of this function this can slow down the whole transfer of data.

This is not a stream command since it returns the current state immediately.

Parameters:

`n` – the 1-based board instance number as returned by `E170X_set_connection()`

`state` – pointer to a variable where the card state has to be written to: a bit pattern of or-concatenated constants specifying the current state:

- `E170X_CSTATE_MARKING` – card is currently marking
- `E170X_CSTATE_PROCESSING` – card has received some data that are enqueued for marking
- `E170X_CSTATE_WAS_START_PRESSED` – the ExtStart input was triggered, this flag is cleared after it has been read and is set again only when ExtStart was triggered again
- `E170X_CSTATE_WAS_STOP_PRESSED` – the ExtStop input was triggered, this flag is cleared after it has been read and is set again only when ExtStop was triggered again
- `E170X_CSTATE_FILE_WRITE_ERROR` – this flag is returned only in case stand-alone data are written to the microSD card and in case an file error occurs during this procedure. As writing an EPR file is done as asynchronous stream, errors during this procedure are not announced by the functions which are called but only by this error state. For more information about writing of stand alone data please refer to section “10.1.5 Writing of stand-alone data”
- `E170X_CSTATE_WAIT_EXTTRIGGER` – the controller is in state “marking” but is not yet processing any data as it is waiting for an external trigger
- `E170X_CSTATE_HALTED` – the controller is in state “marking” but is not yet processing any data as it is currently halted by function `E170X_halt_execution()`
- `E170X_CSTATE_WAIT_INPUT` – the controller is in state “marking” but is not yet processing any data as it is waiting for a specific input pattern at the digital inputs

- `E170X_CSTATE_SAC_READY` - this flag applies only to stand-alone modes; it is similar to output `DOut0` and signals the controller has loaded a stand-alone file and is ready for marking
- `E170X_CSTATE_SAC_MARKING` - this flag applies only to stand-alone modes; it is similar to output `DOut1` and signals the controller is marking a loaded EPR file
- `E170X_CSTATE_SAC_CTLXY` - this flag applies only to stand-alone modes; it signals a “ctlxy” command was received and the related mode is active

When the function returns an error code instead of `E170X_OK`, this value is undefined and can't be used.

Return: `E170X_OK` or an `E170X_ERROR_`-return code in case of an error

**int E170X\_delay(const unsigned char n, double delay)**

Pause marking for the given time.

This is a stream-command, means it is executed at a point in stream that is relative to the other stream commands.

Parameters:

`n` - the 1-based board instance number as returned by `E170X_set_connection()`

`delay` - time to wait until marking continues in unit usec, smallest possible value is 0,500 usecs

Return: `E170X_OK` or an `E170X_ERROR_`-return code in case of an error

**int E170X\_set\_laser\_timing(unsigned char n, double frequency, double pulse)**

Set the frequency and pulse-width to be used during marking at LaserA output.

This is a stream-command, means its parameters are applied at a point in stream that is relative to the other stream commands.

Parameters:

`n` - the 1-based board instance number as returned by `E170X_set_connection()`

`frequency` - emitted frequency in unit Hz and in range 25..20000000 Hz

`pulse` - pulse width in usec, this value has to be smaller than period length that results out of frequency

Return: `E170X_OK` or an `E170X_ERROR_`-return code in case of an error

**int E170X\_set\_standby(const unsigned char n, const double frequency, const double pulse, const bool force)**

Set the frequency and pulse-width to be used during jumps, as stand-by frequency or as continuously running frequency at LaserA output.

This is a stream-command, means its parameters are applied at a point in stream that is relative to the other stream commands.

Parameters:

`n` - the 1-based board instance number as returned by `E170X_set_connection()`

`frequency` - emitted frequency in unit Hz and in range 25..20000000 Hz. When a value of 0 is given, the frequency at LaserA output is turned off at end of mark.

`pulse` - pulse width in usec, this value has to be smaller than period length that results out of `frequency`

`force` - when set to true, the new stand-by frequency is not applied the next time the laser is turned off, but immediately

Return: `E170X_OK` or an `E170X_ERROR_`-return code in case of an error

```
int E170X_set_laserb(const unsigned char n,const double frequency,const double pulse)
```

Set the frequency and pulse-width to be used at LaserB output. To use LaserB as second frequency output, a laser mode with flag `E170X_LASERMODE_DFREQ` has to be configured. This is a stream-command, means its parameters are applied at a point in stream that is relative to the other stream commands.

Parameters:

`n` - the 1-based board instance number as returned by `E170X_set_connection()`

`frequency` - emitted frequency in unit Hz and in range 25..20000000 Hz

`pulse` - pulse width in usec, this value has to be smaller than period length that results out of frequency

Return: `E170X_OK` or an `E170X_ERROR_`-return code in case of an error

```
int E170X_set_fpk(const unsigned char n, double fpk, double yag3QTime)
```

Set the parameters for first pulse killer signal that is emitted via LaserB output whenever the laser is turned on; this applies to YAG-modes only and is emitted as one single pulse at LaserB output. This is a stream-command, means its parameters are applied at a point in stream that is relative to the other stream commands.

Parameters:

`n` - the 1-based board instance number as returned by `E170X_set_connection()`

`fpk` - the length of the first pulse killer signal in usec

`yag3QTime` - the length of the first pulse killer signal in usec, this value is used only when laser mode `E170X_LASERMODE_YAG3` is set, elsewhere it is ignored

Return: `E170X_OK` or an `E170X_ERROR_`-return code in case of an error

```
int E170X_get_free_space(const unsigned char n,int buffer)
```

This function returns the space (in unit "commands") that is free in one of the buffers of E1702. Here parameter `buffer` decides which buffer has to be checked.

Parameters:

`n` - the 1-based board instance number as returned by `E170X_set_connection()`

`buffer` - expects a constant which decides what buffer has to be checked, it has to be set to one of the following values:

- `E170X_FREE_SPACE_PRIMARY` - return size of the primary buffer; it can be used to avoid memory on host system is filled which may happen when vector data are sent to the controller while it's internal buffers are already full. In this case these data would have been stored on host side consuming some memory there. Using this function this problem can be avoided by sending commands only in case this function returns a value that is (much) larger than 0. The primary buffer that can be checked by using this value is one of two available buffers on E1702 controller. The primary one has a size of 900000 and is used to feed the secondary buffer (with a size of 17 million). So when this function returns 900000, this does not mean the buffer is empty and no vector data currently processed - they still may be stored in secondary buffer. So to check the operational state of the controller, only function `E170X_get_card_state()` can be used. This buffer has also to be checked when function `E170X_release_trigger_point()` is used in order to ensure the command can arrive at the controller. For a detailed description please refer to explanation of `E170X_release_trigger_point()` above.
- `E170X_FREE_SPACE_SECONDARY` - return size of the secondary buffer; this one is filled by data from primary buffer and contains raw commands (like single micro vectors that concatenate to a full vector during output).

Return: -1 in case the function failed or the amount of free space in primary buffer.

```
void E170X_get_version(const unsigned char n, unsigned short *hwVersion,  
unsigned short *fwVersion)
```

Get the hardware and software version of the used board. It is recommended to call this function after successful connect always and check if used hardware and firmware version is at least a version that is known to work with own software.

This is not a stream command, it is executed immediately and independent from all other commands.

Parameters:

`n` - the 1-based board instance number as returned by `E170X_set_connection()`

`hwVersion` - pointer to a variable where the hardware revision/version number is written into

`fwVersion` - pointer to a variable where the revision/version number of the firmware running on the board is written into

```
const int E170X_get_library_version()
```

Returns an integer value which is an identifier specifying the version of this shared library. In decimal notation this identifier uses format "Mmmrrr" where "M" is the major version, "m" the minor version number and "r" the release count. The bigger the whole returned number is, the newer the library is.

```
int E170X_get_serial_number(const unsigned char n, char *serial, const int length)
```

Reads the serial number of the used board and returns it as 7 bit ASCII data.

This is not a stream command, it is executed immediately and independent from all other commands.

Parameters:

`n` - the 1-based board instance number as returned by `E170X_set_connection()`

`serial` - pointer to a char-array where the serial number has to be stored into, this memory area needs to have a size of at least 40 bytes

`length` - available length of the memory area where `serial` points to

Return: `E170X_OK` or an `E170X_ERROR_`-return code in case of an error

### 10.1.1 Laser Port Specific Functions

This section describes all functions which are related to the LP8 laser port. On the E1702S controller card, this port is part of the baseboard, thus these functions always can be used without further precondition.

```
int E170X_lp8_write(const unsigned char n, unsigned int flags, unsigned char  
value)
```

Sets the LP8\_0..LP8\_7 outputs of 8 bit laser port without touching the related latch output.

Total execution time of this command during processing on controller is 1 usec.

Depending on the value of parameter `flags` this is either a stream-command (means it is executed at a point in stream that is relative to the other stream commands) or a direct command (means it is executed immediately on calling).

Parameters:

`n` - the 1-based board instance number as returned by `E170X_set_connection()`

`flags` - handling flags specifying the behaviour of this command, `E170X_COMMAND_FLAG_STREAM` to use it as stream command, `E170X_COMMAND_FLAG_DIRECT` to execute it immediately and independent on current stream and execution state

`value` - the 8 bit value to be set at LP8 port

Return: `E170X_OK` or an `E170X_ERROR_`-return code in case of an error

```
int E170X_lp8_write_latch(const unsigned char n, unsigned char on, double delay1, unsigned char value, double delay2, double delay3)
```

Sets the LP8 8 bit laser port with freely definable delays and toggles the related latch output automatically; calling this function causes the following sequence of commands:

- turn latch bit on/off
- wait for `delay1` usecs
- set LP8
- wait for `delay2` usecs
- turn latch bit off/on
- wait for `delay3` usecs

The whole execution time of this sequence on the controller is is 1.5 usecs for setting LP8 outputs and toggling latch plus `delay1` plus `delay2` plus `delay3`. Depending on the value of parameter "on" this function may or may not set the analogue AOut0 output successfully.

This is a stream-command, means it is executed at a point in stream that is relative to the other stream commands.

Parameters:

`n` - the 1-based board instance number as returned by `E170X_set_connection()`

`on` - specifies if the latch bit has to be set to HIGH (`on=1`) or LOW (`on=0`) on first step, on second step it will toggle to value `!on`

`delay1` - delay to be issued after setting/clearing the latch bit for the first time

`value` - the 8 bit value to be set at LP8 port

`delay2` - delay to be issued after setting LP8 output and before clearing/setting the latch bit

`delay3` - delay to be issued after clearing/setting the latch bit for the second time

Return: `E170X_OK` or an `E170X_ERROR_`-return code in case of an error

```
int E170X_lp8_write_mo(const unsigned char n, const unsigned flags, const unsigned char on)
```

Sets or clears the main oscillator output MO to be used with e.g. fiber lasers.

Depending on the value of parameter `flags` this is either a stream-command (means it is executed at a point in stream that is relative to the other stream commands) or a direct command (means it is executed immediately on calling).

Parameters:

`n` - the 1-based board instance number as returned by `E170X_set_connection()`

`flags` - handling flags specifying the behaviour of this command, `E170X_COMMAND_FLAG_STREAM` to use it as stream command, `E170X_COMMAND_FLAG_DIRECT` to execute it immediately and independent on current stream and execution state

`on` - the state the MO output has to be switched to; PLEASE NOTE: the main oscillator depends on the current internal state of the laser. Thus turning it on is always possible but turning off the MO is possible only when the controller is not yet handling the laser-off delay, means it is not possible as long as the laser is turned on. In such a case this command is ignored.

Return: `E170X_OK` or an `E170X_ERROR_`-return code in case of an error

```
int32_t E170X_lp8_write_pilot(const uint8_t n, const uint32_t flags, const uint8_t on)
```

Sets or clears the dedicated pilot laser output.

Depending on the value of parameter `flags` this is either a stream-command (means it is executed at a point in stream that is relative to the other stream commands) or a direct command (means it is executed immediately on calling).

Parameters:

`n` - the 1-based board instance number as returned by `E170X_set_connection()`

`flags` - handling flags specifying the behaviour of this command, `E170X_COMMAND_FLAG_STREAM` to use it as stream command, `E170X_COMMAND_FLAG_DIRECT` to execute it immediately and independent on current stream and execution state

`on` - the state the pilot laser output has to be switched to; PLEASE NOTE: pilot laser emission often depends on the current internal state of the laser. Thus turning it on may depend on additional conditions and/or a specific state of the laser which typically is described in the manual of that laser.

Return: `E170X_OK` or an `E170X_ERROR_`-return code in case of an error

## 10.1.2 Digital IO Functions

In this section all functions are described which make use of the optional digital in- and outputs of the Digi IO extension board. When this board is not available, all these functions will fail with an error code

`E170X_ERROR_BORD_NA`.

**`int E170X_digi_write(const unsigned char n, unsigned int flags, unsigned int value, unsigned int mask)`**

Sets the 8 bit digital output port of Digi I/O Extension Board.

Depending on the value of parameter `flags` this is either a stream-command (means it is executed at a point in stream that is relative to the other stream commands) or a direct command (means it is executed immediately on calling).

Parameters:

`n` - the 1-based board instance number as returned by `E170X_set_connection()`

`flags` - handling flags specifying the behaviour of this command, `E170X_COMMAND_FLAG_STREAM` to use it as stream command, `E170X_COMMAND_FLAG_DIRECT` to execute it immediately and independent on current stream and execution state

`mask` - specifies which of the bits in "value" have to be used for setting and clearing output data, only these bits that are set to 1 in `mask` are changed according to the given `value`

`value` - the 8 bit value to be set at digital out port

Return: `E170X_OK` or an `E170X_ERROR_` return code in case of an error

**`int E170X_digi_pulse(const unsigned char n, const unsigned int flags, const unsigned int in_value, const unsigned int mask, const unsigned int pulses, const double delayOn, const double delayOff)`**

Send a sequence of pulses to the 8 bit digital output port of Digi I/O Extension Board. Comparing to a self-generated sequence of pulses, this operation causes nearly no data transmission load.

This command is available as stream-command only (means it is executed at a point in stream that is relative to the other stream commands).

Parameters:

`n` - the 1-based board instance number as returned by `E170X_set_connection()`

`flags` - currently only `E170X_COMMAND_FLAG_STREAM` is supported here

`mask` - specifies which of the bits in "value" have to be used for setting and clearing output data, only these bits that are set to 1 in `mask` are changed according to the given `value`

`value` - the 8 bit value to be set at digital out port

`pulses` - specifies how often the output has to be set/cleared

`delayOn` - the delay (in unit usec) which has to be issued every time after setting the output, the minimal resolution of this value is 0,5 usec

`delayOff` - the delay (in unit usec) which has to be issued every time after clearing the output, the minimal resolution of this value is 0,5 usec

Return: `E170X_OK` or an `E170X_ERROR_` return code in case of an error

```
int E170X_digi_read(const unsigned char n,const unsigned char flags,unsigned int *value)
```

Reads the 8 bit digital input port of Digi IO Extension Board.

This is not a stream-command, means it is executed immediately and returns current known state of the digital inputs.

When parameter `flags` is set to 0, the state of the digital inputs is requested actively which results in a separate data transmission to the controller card. On excessive use of this command, that may slow down communication with the controller dramatically. Alternatively `flags` can be set to `E170X_COMMAND_FLAG_PASSIVE` which does not cause such a request. Instead of this the last known state of the digital inputs is returned by this function based on the last regular feedback from the controller or based on the last call to this function with this passive-flag not set. So when this `flags` is used, the returned `value` may be several hundred milliseconds old.

When marking on the fly is enabled using function `E170X_digi_set_motf()`, digital inputs 0 and 1 and optionally also digital inputs 2 and 3 are used for MOTF-encoder and therefore not available as standard inputs. In this case state of these bits is undefined and does not reflect the current input state caused by the external encoder.

Parameters:

`n` - the 1-based board instance number as returned by `E170X_set_connection()`

`value` - pointer to a variable where the current digital input state has to be written into.

When the function returns an error code instead of `E170X_OK`, this value is undefined and can't be used.

Return: `E170X_OK` or an `E170X_ERROR_`-return code in case of an error

```
int E170X_digi_wait(const unsigned char n,unsigned long value,unsigned long mask)
```

Stop execution and output of data until the given bitpattern was detected at digital inputs of Digit I/O Extension board. Here parameter `mask` specifies which of the bits at the input have to be checked, they have to be set to 1. These bits within `mask` that need to be ignored have to be set to 0. Parameter `value` itself defines the states of the bits that has to be detected at the input to continue processing of data. All bits of `value` that correspond to bits of `mask`, that are 0, are ignored.

Parameters:

`n` - the 1-based board instance number as returned by `E170X_set_connection()`

`value` - the expected bitpattern at digital input

`mask` - specifies which of the input bits and value bits have to be used for comparison

Return: `E170X_OK` or an `E170X_ERROR_`-return code in case of an error

```
int E170X_digi_set_motf(const unsigned char n, double motfX, double motfY)
```

Disables or enables marking on-the-fly functionality and specifies factors for X- and Y-direction. When this function is called with values for `motfX` or `motfY` greater than 0, marking on-the-fly is enabled and digital inputs 0 and 1 of DigiIO Extension Board are no longer available as general purpose inputs. Now they are used as decoder inputs for a 90 degree phase shifted encoder signal for marking on-the-fly applications. When both parameters `motfX` and `motfY` are set to 0, marking on-the-fly is disabled and inputs 0 and 1 no longer work as encoder inputs.

When tune flag "2" is set, the two factors for X and Y are assigned to separate encoder inputs. Here factor for X applies to values received on digital inputs 0 and 1 and factor for Y applies to values received on digital inputs 2 and 3.

This is not a stream-command, means it switches states of digital inputs 0 and 1 (plus optionally 2 and 3) and marking on-the-fly functionality immediately.

Parameters:

`n` - the 1-based board instance number as returned by `E170X_set_connection()`

`motfX` - marking on-the-fly factor for X-direction in unit bits per encoder increment

`motfY` - marking on-the-fly factor for Y-direction in unit bits per encoder increment

Return: `E170X_OK` or an `E170X_ERROR_`-return code in case of an error

```
int E170X_digi_set_motf_sim(const unsigned char n, double motfX, double motfY)
```

Disables or enables simulated marking on-the-fly functionality and specifies factors for X- and Y-direction. When this function is called with values for `motfX` or `motfY` greather than 0, simulated marking on-the-fly is enabled and internal 100 kHz signal generator is used to create static marking on-the-fly pulses in positive direction. A possibly enabled on-the-fly operation using external signals on digital inputs 0 and 1 of Digi I/O Extension Board is disabled. When both parameters `motfX` and `motfY` are set to 0, marking on-the-fly simulation is disabled completely.

This is not a stream-command, means it enables simulated marking on-the-fly functionality immediately.

Parameters:

`n` - the 1-based board instance number as returned by `E170X_set_connection()`

`motfX` - marking on-the-fly factor for X-direction in unit bits suitable for to be simulated movement-speed on 100 kHz encoder counting frequency

`motfY` - marking on-the-fly factor for Y-direction in unit bits suitable for to be simulated movement speed on 100 kHz encoder counting frequency

Return: `E170X_OK` or an `E170X_ERROR_`-return code in case of an error

```
int E170X_digi_wait_motf(const unsigned char n, const unsigned int flags, const double dist)
```

Halts the current marking operation for a given distance of the on-the-fly encoder. Different to `E170X_delay()` this function does not use a time to wait until marking is continued but a distance specified by parameter `dist` and measured by the connected encoder. To use this function marking on-the-fly has to be enabled by calling `E170X_digi_set_motf()` or `E170X_digi_set_motf_sim()` before.

This command is useful for marking on-the-fly applications where several vector data have to be marked which in total are larger than the available working area of the scanhead (e.g. when marking long texts on a cable). For this the vector data to be marked have to be concatenated in suitable pieces where each piece is smaller than the available working area. Then these pieces can be marked consecutively with following sequence of commands:

1. `E170X_set_trigger_point()` (used only once at the very beginning to define the starting point and to initialise internal MOTF counters). This trigger point later has to be released either by applying an ExtStart signal or by calling function `E170X_release_trigger_point()`
2. `E170X_digi_wait_motf()` to wait for the beginning of the first piece of vector data to be marked, the given distance is equal to the distance from the starting point in 1)
3. `E170X_jump_abs()/E170X_mark_abs()` for vector data of character to be marked; here one piece of the whole set of vector data has to be sent to the controller
4. `E170X_digi_wait_motf()` to wait for the distance until next set of vector data; here the distance between the starting points of two pieces of vector data has to be given
5. continue at 3) until all pieces of vector data have been sent

This is a stream-command, means it is executed at a point in stream that is relative to the other stream commands.

Parameters:

`n` - the 1-based board instance number as returned by `E170X_set_connection()`

`flags` - specifies how the distance value is handed over, with `E170X_COMMAND_FLAG_MOTF_WAIT_INCS` a value in unit "encoder increments" is expected, with `E170X_COMMAND_FLAG_MOTF_WAIT_BITS` a distance in unit "bits" is expected. In second case the X-on-the-fly factor of a preceding call to `E170X_digi_set_motf()` or `E170X_digi_set_motf_sim()` is used.

`dist` - the distance to wait for until marking has to be completed, the unit of this value is specified with preceding parameter `flags`

Return: `E170X_OK` or an `E170X_ERROR_`-return code in case of an error

```
int E170X_digi_set_mip_output(const unsigned char n, unsigned int value, unsigned int flags)
```

This function can be used to specify which of the digital outputs has to be used for signalling "marking in progress". When `value` is set to `0xFFFFFFFF0`, this function is disabled and scanner controller card does not provide this signal automatically. When the number of the digital output (in range 0..7) is given as `value`, the related digital output pin is used for "mark in progress" signal. When the given number is `0xFFFFFFFF` and when LaserB output is used as general purpose output (as it can be done by using the tune-flags), the LaserB output pin is used as for signalling the marking-state.



PLEASE NOTE: here the number (means the count) of one specific output pin has to be given, not a bitpattern specifying one or more pins!

During operation the selected "mark in progress" pin is HIGH as long as the scanner is moving and/or the laser is on and/or a delay is processed and when marking parameter are processed between these operations. It becomes LOW as soon as no more marking data are available and current operation is stopped or when scanner is waiting for an external trigger signal (ExtStart).

This is not a stream-command, when it is called it is applied to current configuration immediately.

Parameters:

`n` - the 1-based board instance number as returned by `E170X_set_connection()`

`value` - the number of the digital output to be used for this signal

`flags` - currently unused, set always to 0 for compatibility

Return: `E170X_OK` or an `E170X_ERROR_`-return code in case of an error

```
int E170X_digi_set_wet_output(const unsigned char n, const unsigned int value, const unsigned int flags)
```

This function can be used to specify which of the digital outputs has to be used for signalling "waiting for external trigger". When `value` is set to `0xFFFFFFFF0`, this function is disabled and scanner controller card does not provide this signal automatically. When the number of the digital output (in range 0..7) is given as `value`, the related digital output pin is used for "waiting for external trigger" signal. When the given number is `0xFFFFFFFF` and when LaserB output is used as general purpose output (as it can be done by using the tune-flags), the LaserB output pin is used as for signalling the marking-state.



PLEASE NOTE: here the number (means the count) of one specific output pin has to be given, not a bitpattern specifying one or more pins!

During operation the selected "waiting for external trigger" pin is HIGH as long as the controller is waiting for an external trigger to be applied at ExtStart input. It becomes LOW as soon as this signal has been detected or when current operation is stopped.

This is not a stream-command, when it is called, it is applied to current configuration immediately.

Parameters:

`n` - the 1-based board instance number as returned by `E170X_set_connection()`

`value` - the number of the digital output to be used for this signal

`flags` - currently unused, set always to 0 for compatibility

Return: `E170X_OK` or an `E170X_ERROR_`-return code in case of an error

### 10.1.3 Stepper Motor Motion Functions

The E1702S can be used to control up to four stepper motor axes via step/direction signals emitted at fixed output of the Digi I/O extension board. The axes and signals are assigned in the following way:

| Axis | Step-Output | Direction Output |
|------|-------------|------------------|
| 0    | DOut0       | DOut4            |
| 1    | DOut1       | DOut5            |
| 2    | DOut2       | DOut6            |
| 3    | DOut3       | DOut7            |

Start/end of a motion operation can be checked by calling `E170X_get_card_state()`, here "running motion" is signalled as "marking". When the function returns "idle", a motion operation has been completed.

An example that demonstrates the usage of the stepper motor functions can be found online at [https://sourceforge.net/p/oapc/code/ci/master/tree/libe170x/libe170x\\_test\\_motion/](https://sourceforge.net/p/oapc/code/ci/master/tree/libe170x/libe170x_test_motion/)

When no Digi I/O extension board is not available, all these functions will fail with an error code

```
E170X_ERROR_BORD_NA.
```

```
int E170X_digim_set_accels(const unsigned char n,const unsigned char axis,const double accel)
```

With this function an acceleration value can be set which is used whenever a motion starts and ends. As these motion functions make use of a logarithmic acceleration mode only, the `accel`-value is not specified by a value which has a defined measurement unit. The value given here is some kind of step-based factor. The higher the value is, the stronger the acceleration/deceleration will be. When set to 0, no acceleration will take place and all motions will start with full speed immediately.

Parameters:

`n` - the 1-based board instance number as returned by `E170X_set_connection()`

`axis` - the axis identifier in range 0..3

`accel` - the acceleration to be set for this axis

Return: `E170X_OK` or an `E170X_ERROR_`-return code in case of an error

```
int E170X_digim_set_limits(const unsigned char n,const unsigned char axis,const int llimit,const int hlimit,const unsigned int slimit)
```

Set maximum movement range and speed limit for all subsequent motion commands. So no matter what following calls to set a speed or to go to a motion position will specify, the limits defined here never can be exceeded.

Parameters:

`n` - the 1-based board instance number as returned by `E170X_set_connection()`

`axis` - the axis identifier in range 0..3

`llimit` - the lower motion position (in unit steps) this axis can be moved to

`hlimit` - the upper motion position (in unit steps) this axis can be moved to

`slimit` - the maximum speed (in unit steps/second) this axis can be moved with

Return: `E170X_OK` or an `E170X_ERROR_`-return code in case of an error

```
int E170X_digim_set_speed(const unsigned char n,const unsigned char axis,double speed)
```

Set the speed for the next motion command. This call specifies at which speed the related axis will be moved.

Parameters:

`n` - the 1-based board instance number as returned by `E170X_set_connection()`

`axis` - the axis identifier in range 0..3

`speed` - the speed (in unit steps/second) the axis will be moved with on next motion

Return: `E170X_OK` or an `E170X_ERROR_`-return code in case of an error

```
int E170X_digim_move_abs(const unsigned char n,const unsigned char axis,const int pos)
```

This function moves an axis to the given position by using the speed that was defined by a preceding call to `E170X_digim_set_speed()`. This function causes a movement immediately which sets the

controller to state “marking”. So after this call, function `E170X_get_card_state()` has to be called to check if the controller is active and to check if the controller is back in state “idle”.

Parameters:

`n` – the 1-based board instance number as returned by `E170X_set_connection()`  
`axis` – the axis identifier in range 0..3  
`pos` – the absolute position (in unit steps) the axis has to be moved to

Return: `E170X_OK` or an `E170X_ERROR_`-return code in case of an error

```
int E170X_digim_move_rel(const unsigned char n,const unsigned char axis,const int pos)
```

This function changes the position of an axis by the given amount by using the speed that was defined by a preceding call to `E170X_digim_set_speed()`. This function causes a movement immediately which sets the controller to state “marking”. So after this call, function `E170X_get_card_state()` has to be called to check if the controller is active and to check if the controller is back in state “idle”.

Parameters:

`n` – the 1-based board instance number as returned by `E170X_set_connection()`  
`axis` – the axis identifier in range 0..3  
`pos` – the relative position (in unit steps) the axis has to be moved by

Return: `E170X_OK` or an `E170X_ERROR_`-return code in case of an error

```
int E170X_digim_set_pos(const unsigned char n,const unsigned char axis,const int pos)
```

Comparing to the preceding functions, this one does not cause any movement. It sets the internal position of the axis to the given value in order to have the controller in a defined state. So this function should be called whenever the axis is located at a defined position where a defined position value has to be assigned to.

Parameters:

`n` – the 1-based board instance number as returned by `E170X_set_connection()`  
`axis` – the axis identifier in range 0..3  
`pos` – the internal position (in unit steps) which has to be set to the current mechanical position of the axis

Return: `E170X_OK` or an `E170X_ERROR_`-return code in case of an error

## 10.1.4 Miscellaneous functions

```
int E170X_write(const unsigned char n,unsigned int flags,unsigned int value)
```

Writes some specific data to outputs at E1702S controller. Here `flags` decides which output to use and `value` specifies what has to be written to this output. Additionally `flags` decides whether this is a stream-command (means it is executed at a point in stream that is relative to the other stream commands) or a direct command (means it is executed immediately on calling).

Parameters:

`n` – the 1-based board instance number as returned by `E170X_set_connection()`  
`flags` – handling flags specifying the behaviour of this command, when `E170X_COMMAND_FLAG_STREAM` is set, it is used as stream command, `E170X_COMMAND_FLAG_DIRECT` specifies to execute it immediately and independent on current stream and execution state. Here exactly one of these two flags can be used, it is not allowed to OR-concatenate them. Additionally exactly one of the following flags has to be set to specify which output need to be used to send the `value` to, this flag has to be OR-concatenated with one of the previously described ones:

- `E170X_COMMAND_FLAG_WRITE_LP8MO` – set or unset MO-output to a value of 1 or 0
- `E170X_COMMAND_FLAG_WRITE_LP8LATCH` – set or unset latch-output to a value of 1 or 0
- `E170X_COMMAND_FLAG_WRITE_LASERA_GPO` – set or unset LaserA-output to a value of 1 or 0, this option requires the LaserA output to be configured as GPO-output; for details please refer to description of "tune" parameters
- `E170X_COMMAND_FLAG_WRITE_LASERB_GPO` – set or unset LaserB-output to a value of 1 or 0, this option requires the LaserB output to be configured as GPO-output; for details please refer to description of "tune" parameters
- `E170X_COMMAND_FLAG_WRITE_LASERGATE` – set or unset LaserGate-output to a value of 1 or 0, this functions should be used with jump or mark operations only since every switch from jump to mark (or vice versa) still sets the LaserGate output automatically and therefore would overwrite own values set with this function

value – the value to be sent to the output specified by flags

Return: `E170X_OK` or an `E170X_ERROR_`-return code in case of an error

## 10.1.5 Writing of stand-alone data

Using E1702 Easy Programming Interface it is also possible to write stand-alone data which are not marked immediately but are stored either locally or on scanner controller's micro-SD-card. In this mode sending of vector data, scanner- and laser parameters looks exactly the same as for direct operation mode where data are marked immediately. The difference can be found in initialisation (which tells the software to not to mark these data but to store them for later use) and when dynamic data are created.

E1702 supports two types of writing of stand-alone data:

- sending them to the controller via Ethernet or USB connection where they are written to micro-SD-card and
- writing one or more files to the local file system which later have to be copied to the micro-SD-card of the controller manually.

The general procedure for sending stand-alone data to the controller's micro-SD-card has to look as follows:

1. The controller needs to be in idle-state, means it should not mark and should not have loaded an already existing .EPR file. This can be ensured by calling stand-alone command `clepr` with a filename for a file that does not exists on micro-SD-card. For more details please refer to “8.2 Stand-Alone Control Commands”
2. Configure the connection to E1702 controller by calling `E170X_set_connection()`, the returned board instance number has to be used for all following function calls.
3. Enable stand-alone write mode and specify the filename of the .EPR file to be created on micro-SD-card by calling `E170X_set_filepath()` with mode `E170X_FILEMODE_SEND`.
4. Send all laser- and scanner-parameters as well as vector data as usual.
5. Optionally: send information about dynamic contents of the .EPR file to be created by calling `E170X_dynamic_data2()` optionally followed by some vector data followed by an other call to function `E170X_dynamic_data2()` which ends this section of dynamic data (please refer function description below for details).
6. Wait until `E170X_get_card_state()` returns “busy”
7. Wait until `E170X_get_card_state()` returns “idle” or an error
8. End data transmission and finish created file by calling `E170X_close()`.

The general procedure for writing stand-alone data to the local filesystem has to look as follows:

1. Since writing of local data does not require a working connection to the controller card, it does not need to be configured and the special board instance number 0 has to be used for all following function calls.
2. Enable stand-alone write mode and specify the filename of the .EPR file to be created by calling `E170X_set_filepath()` with mode `E170X_FILEMODE_LOCAL`.
3. Send all laser- and scanner-parameters as well as vector data as usual.
4. Optionally: send information about dynamic contents of the .EPR file to be created by calling `E170X_dynamic_data2()` optionally followed by some vector data followed by an other call to

function `E170X_dynamic_data2()` which ends this section of dynamic data (please refer function description below for details).

5. End data transmission and finish created file by calling `E170X_close()`.

The functions which are specific to writing of stand-alone data have to be used as follows:

```
int E170X_set_filepath(const unsigned char n,const char *fname,unsigned int mode)
```

This function enables operation mode where all following data are not marked immediately but written into an .EPR stand-alone file. This mode stays active until next call of `E170X_close()`. It has to be called prior to `E170X_load_correction()`. Valid parameters and their meaning depends on the usage scenario:

- when sending stand-alone data to a connected controller which writes the .EPR file to the micro-SD-card directly:  
n - the 1-based board instance number as returned by `E170X_set_connection()`  
fname - name of the file as it has to appear on micro-SD-card of the controller in style "0:/filename.epr" where "0:/" is a fixed prefix specifying the micro-SD-card, "filename" is a free to choose name with recommended 8 characters at max and ".epr" is a fixed, mandatory file extension specifying an E1702 stand-alone file  
mode - set to `E170X_FILEMODE_SEND` to specify the data have to be sent to the controller
- when writing stand-alone data to the local filesystem (no controller card directly involved):  
n - board instance number, has to be set to 0 (as well as for all other function calls in this mode)  
fname - name of the file to be written, this has to be a valid path to a location on a local filesystem which is writable and needs to have file extension ".epr"  
mode - set to `E170X_FILEMODE_LOCAL` to specify the data have to be written locally

Return: `E170X_OK` or an `E170X_ERROR_`-return code in case of an error

```
int E170X_dynamic_data2(const unsigned char n,struct oapc_bin_struct_dyn_data2 *dynData)
```

This function can be used to write dynamic data such as texts, serial numbers, barcodes which later can be changed during operation in stand-alone mode.

This function always has to be called in fixed sequences:

1. jump to the start position of the dynamic element by calling `E170X_jump_abs()`
2. first call of `E170X_dynamic_data2(n,dynData)` with a valid `dynData` parameter describing the dynamic content and its capabilities
3. optionally and dependent on type of dynamic data that have to be created: some vector data which belong to the dynamic content and are required to build it up
4. second call of `E170X_dynamic_data2(n,NULL)` with NULL handed over for parameter `dynData` to finish this element

A stand-alone file can contain up to ten dynamic data elements. So this function can be called up to ten times to create a new element on each call.

When this function is called, beside the .EPR-file an additional .DAT file is created which contains some specific data. During operation in stand-alone mode an other file with the same name and with extension .SER may be created which contains counting information of an included serial number. All these files belong together and deleting one or more of them may lead to unexpected results. When writing the data to local filesystem it also has to be ensured both, the .EPR and the .DAT file are copied to the controller later.

The structure `oapc_bin_struct_dyn_data2` is defined in file "oapc\_libio.h" which is part of the OpenSDK. The general usage is described in OpenSDK manual, both are available for download at <https://halaser.systems/download.php>.

For E1702 scanner controller card following specific parameters and features of this structure can to be used:

Independent from what kind of dynamic element has to be created, following members of structure `oapc_bin_struct_dyn_data2` **always have to be filled** with data:

UID – and unique identifier which can be created out of a plain, human readable text which should be unique too and later can be used to access this specific element via stand-alone control commands; this identifier has to be created out of the 8 bit ASCII character using following CRC-function:

```
#define POLY 0x82f63b78

/* CRC-32 (Ethernet, ZIP, etc.) polynomial in reversed bit order. */
unsigned int crc32b(const char *buf)
{
    int k;
    unsigned int crc=0xFFFFFFFF;
    size_t len=strLen(buf);

    while (len--)
    {
        crc^=*buf++;
        for (k=0; k<8; k++)
            crc=crc&1 ? (crc>>1)^POLY : crc>>1;
    }
    return ~crc;
}
```

uScaleX – scaling factor in X-direction in unit 1/1000000

uScaleY – scaling factor in Y-direction in unit 1/1000000

res1a, res1b, res2, res3, res4, res5, res6, res7 – these members are reserved for later use and all have to be set to 0

Every dynamic element can be a **serial number**. In such a case the serial number part of structure `oapc_bin_struct_dyn_data2` has to be filled with data:

`fmtString` – an ASCII text with a maximum length of `DYN_DATA_MAX_STRING_LENGTH` describing the format of the serial number/date/time in the dynamic element, here the same notation has to be used as it is known from the serial number input element of BeamConstruct (please refer to the related manual)

`snBeatCount` – specifies how much numbers of mark operations have to elapse before the serial number has to be incremented, here a value of 1 has to be given to increment on every operation

`snBeatOffset` – specifies a counting offset for the beat count parameter

`snIncrement` – specifies the step width by which a serial number has to be incremented

`snNumericBase` – the numeric base of the serial numbers to be displayed, default is 10 for decimal numbers

`snResetAtTime` – the time value at which the serial number has to be reset to it's initial value; set to a timestamp (in unit day of week/date/seconds) when it has to be reset at a given time

`snResetAtValue` – the numeric value at which the serial number has to be reset to it's initial value

`snFlags` – a set of OR-concatenated flags which further specifies handling of the serial number:

0x0002 – reset the serial number at a specific counting value specified by `snResetAtValue`

0x0004 – reset the serial number at a specific day of the week specified by `snResetAtTime`

0x0008 – reset the serial number at a specific date specified by `snResetAtTime`

0x0010 – reset the serial number at a specific time of the day specified by `snResetAtTime`

`snStartValue` – the initial- and reset-to-value of the serial number

`snMinDigits` – the minimum number of digits the serial number has to consist of

`timeOffset` – a static offset (in unit seconds) to be added to the time-part of the current element

Dynamic text elements additionally need to fill following parts of the same structure

`oapc_bin_struct_dyn_data2`:

`fmtString` – an ASCII text with a maximum length of `DYN_DATA_MAX_STRING_LENGTH` which contains the text to be shown and which can be changed by appropriate stand-alone commands later; when used in combination with serial number data, here a format-string has to be given as described above

`type` – a number which specifies the font to be used for creating the dynamic texts, here one of following values can be used:

- 0x01000000 – use “Rect Single” laser font
- 0x02000000 – use “Rect Double” laser font
- 0x03000000 – use “Roman Simple” laser font
- 0x04000000 – use “Roman Double” laser font
- 0x05000000 – use “Script Simple” laser font
- 0x06000000 – use “Script Double” laser font
- 0x07000000 – use “Script Complex” laser font
- 0x08000000 – use “Times Simple” laser font
- 0x09000000 – use “Times Bold” laser font
- 0x0A000000 – use “Times Italic” laser font
- 0x0B000000 – use “Times Italic Bold” laser font

`flags` – some OR-concatenated flags which specify orientation, alignment and style of the text to be generated, here no two flags of same type are allowed to be combined which would conflict with each other:

- 0x00000000 – orient text left to right
- 0x00010000 – orient text right to left
- 0x00020000 – orient text top to bottom
- 0x00030000 – orient text bottom to top
  
- 0x00000000 – horizontally align to the left
- 0x00000100 – centre-align horizontally
- 0x00000200 – horizontally align to the right
  
- 0x00000001 – style fixed char-size – all characters are forced to have same distance

`param1` – kerning value in unit 1/1000%

`param2` – reserved for future use, set to 0

`param3` – spacing in unit 1/1000%

**Dynamic DataMatrix barcode elements** require vector data to be sent between two calls of function `E170X_dynamic_data2()`, these vector data describe the pattern which has to be marked to create one single element (means square) of the DataMatrix barcode. Such an element needs to incorporate all that is needed including laser- and scannerdata as well as vector data for outline and possible hatches. During stand-alone operation the barcode itself is created by combining these single elements at these positions, where a bit (=square) has to be set).

Additionally following data of the structure `oapc_bin_struct_dyn_data2` need to be filled for this type of element:

`fmtString` – an ASCII text with a maximum length of `DYN_DATA_MAX_STRING_LENGTH` which contains the text to be encoded as DataMatrix barcode and which can be changed by appropriate stand-alone commands later; when used in combination with serial number data, here a format-string has to be given as described above

`type` – set to 71 for DataMatrix barcode

`flags` – some OR-concatenated flags which further specify how the barcode has to be created, currently only one flag is supported:

- 0x0001 – create a square-shaped DataMatrix barcode instead of a rectangular one

`param1` – set to 0

`param2` – set to -1

`param3` – specifies the size to be generated (in range 2..30) and implicitly the error correction level

`quietZone` – zone the barcode has to be surrounded with, the value given here is the multiple of the width of a single token multiplied with 1000

### ***10.1.5.1 Example***

Following a (simplified) example in some pseudo-code is given which demonstrates the correct usage of the programming interface to write stand-alone data. The laser- and scanner-parameters are dropped in this example since they are not specific to this operation mode and always have to be set.

Example: A serial number in format "000/hh/mm" where "000" is a continuously increased number, "hh" is the current hour and "mm" is the current minute has to be encoded into a DataMatrix barcode which has a size of 25x25 mm and is positioned at -30x30 mm within a 100x100 mm working area that itself is aligned to coordinates -50,50

1. not shown here: initialisation of libe1702 (with evaluation of parameter `boardIdx`), sending of default scanner and laser data as usual
2. `E170X_jump_abs(boardIdx, -20132659, 20132659, 0)` //jump to the starting position of the DataMatrix barcode to be created
3. `E170X_dynamic_data2(boardIdx, dynData)` // initiate the dynamic data sequence, here the members of `dynData` are set to following values:
  - `UID` = 2340633892 - CRC-value of element name "Barcode 1"
  - `fmtString` = "\$S/%I/%M" - display serial number, hour and minute
  - `type` = 71 - DataMatrix barcode
  - `flags` = 1 - barcode forced to square
  - `param2` = 4294967295
  - `param3` = 2
  - `uScaleX` = 1029654
  - `uScaleY` = 1029654
  - `snIncrement` = 1
  - `snNumericBase` = 10
  - `snMinDigits` = 3

all other values are set to 0
4. `E170X_jump_abs(boardIdx, 0, 0, 0)`  
`E170X_mark_abs(boardIdx, 1197222, 0, 0)`  
`E170X_mark_abs(boardIdx, 1197222, -1197222, 0)`  
`E170X_mark_abs(boardIdx, 0, -1197222, 0)`  
`E170X_mark_abs(boardIdx, 0, 0, 0)` // draw a single rectangle which describes one DataMatrix cell (in this example only the outline without any hatching is done, hatches would have to be added here too)
5. `E170X_dynamic_data2(boardIdx, NULL)` // end the sequence of dynamic data
6. `E170X_execute(boardIdx)`
7. Not shown here: waiting for card being busy, waiting for card being idle (which means writing of the Epr file to the microSD card has been finished), closing the connection to the controller

### 10.1.6 Error Codes

Most of the functions described above can return an error code in case an operation could not be completed successfully for any reason. So when it does not return with `E170X_OK` the error code informs about the reason for failure:

- `E170X_ERROR_INVALID_CARD` - a wrong or illegal card number was specified with function parameter `n`
- `E170X_ERROR_NO_CONNECTION` - a connection to card could not be established
- `E170X_ERROR_NO_MEMORY` - there is not enough memory available on the host to perform the requested operation
- `E170X_ERROR_UNKNOWN_FW` - card is running an unknown and/or incompatible firmware version
- `E170X_ERROR_TRANSMISSION` - data transmission to card failed
- `E170X_ERROR_FILEOPEN` - opening of a file failed
- `E170X_ERROR_FILEWRITE` - writing of data into a file failed
- `E170X_ERROR_BORD_NA` - a base- or extension board that would be required for a function is not available
- `E170X_ERROR_INVALID_DATA` - data or parameters handed over to a function are invalid, out of range or illegal in current context

- E170X\_ERROR\_UNKNOWN\_BOARD - trying to access a controller board that is not a suitable controller
- E170X\_ERROR\_FILENAME - a file name handed over to a function was illegal, it is either too long, has an illegal or too long file extension, comes with too much sub-directories or contains illegal characters
- E170X\_ERROR - an other, unspecified error occurred
- E170X\_ERROR\_NOT\_SUPPORTED - the requested feature or function is not supported by the current firmware version
- E170X\_ERROR\_STILL\_IN\_PROGRESS - the requested function could not be executed because the controller is still busy, this happens e.g. in cases where a stand-alone operation is running on the controller which is not under control of the programming interface

# APPENDIX A – Wiring between E1702S and specific laser types

This appendix describes the wiring between the controller card and specific laser models when the E170Xdock (as described in “6.4 E1702Sdock Extension Board”) is not used or when it can’t be used because the laser comes with a non-standard, proprietary control interface.

## Wiring between E1702S and IPG YLP Series Type B, B1 and B2, GZTech YFPN series fiber laser

 PLEASE NOTE: this wiring scheme is a non-binding policy, it may be incorrect due to changes in connected hardware. So in every case please check this table against specification and wiring documentation of the used laser!

Variant using E1702S and optional Digi I/O Extension Board for laser alarms.

| Signal Name                  | Board                    | Connector / Pin                   | IPG Pin   |
|------------------------------|--------------------------|-----------------------------------|-----------|
| LP0                          | E1702S Baseboard         | Pin 9                             | Pin 1     |
| LP1                          |                          | Pin 11                            | Pin 2     |
| LP2                          |                          | Pin 13                            | Pin 3     |
| LP3                          |                          | Pin 15                            | Pin 4     |
| LP4                          |                          | Pin 17                            | Pin 5     |
| LP5                          |                          | Pin 19                            | Pin 6     |
| LP6                          |                          | Pin 21                            | Pin 7     |
| LP7                          |                          | Pin 23                            | Pin 8     |
| LP8 Latch                    |                          | Pin 25                            | Pin 9     |
| MO / Main Oscillator         |                          | Pin 18                            | Pin 18    |
| LaserA / Frequency           |                          | Pin 22                            | Pin 20    |
| Laser Gate / Modulation      |                          | Pin 20                            | Pin 19    |
| Pilot                        |                          | Pin 16                            | Pin 22 *) |
| Alarm,<br>one of DIn0...DIn7 | Digi I/O Extension Board | Pin 4, 6, 8, 10, 12, 14, 16 or 18 | Pin 16    |
| Alarm,<br>one of DIn0..DIn7  |                          | Pin 4, 6, 8, 10, 12, 14, 16 or 18 | Pin 21    |

 \*) may require additional power driver since some laser variants consume a current at this input which is higher than the maximum output allowed

In this wiring-scheme no GND-connections are listed, they have to be added in order to get valid and working connections.

## Wiring between E1702S and JPT YDFLP series fiber laser (“MOPA”) or IPG YLP Series Type D fiber laser or Raycus RFL PMX/PQB Series fiber laser



PLEASE NOTE: this wiring scheme is a non-binding policy, it may be incorrect due to changes in connected hardware. So in every case please check this table against specification and wiring documentation of the used laser!

Variant using E1702S and optional Digi I/O Extension Board for laser alarms.

| Signal Name                  | Board                    | Connector / Pin                   | JPT D-SUB25 Pin      |
|------------------------------|--------------------------|-----------------------------------|----------------------|
| LP0                          | E1702S Baseboard         | Pin 9                             | Pin 1                |
| LP1 / serial data            |                          | Pin 11                            | Pin 2 <sup>2)</sup>  |
| LP2 / serial clock           |                          | Pin 13                            | Pin 3 <sup>2)</sup>  |
| LP3                          |                          | Pin 15                            | Pin 4                |
| LP4                          |                          | Pin 17                            | Pin 5                |
| LP5                          |                          | Pin 19                            | Pin 6                |
| LP6                          |                          | Pin 21                            | Pin 7                |
| LP7                          |                          | Pin 23                            | Pin 8                |
| LP8 Latch                    |                          | Pin 25                            | Pin 9                |
| MO / Main Oscillator         |                          | Pin 18                            | Pin 18               |
| LaserA / Frequency           |                          | Pin 22                            | Pin 20               |
| Laser Gate / Modulation      |                          | Pin 20                            | Pin 19               |
| Pilot / serial enable        |                          | Pin 16                            | Pin 22 <sup>1)</sup> |
| Alarm,<br>one of DIn0...DIn7 | Digi I/O Extension Board | Pin 4, 6, 8, 10, 12, 14, 16 or 18 | Pin 16               |
| Alarm,<br>one of DIn0...DIn7 |                          | Pin 4, 6, 8, 10, 12, 14, 16 or 18 | Pin 21               |

<sup>1)</sup> for details regarding double-usage of this pin, please refer to the manual of the laser

In this wiring-scheme no GND-connections are listed, they have to be added in order to get valid and working connections.

## Wiring between E1702S and IPG YLP Series Type E fiber laser



PLEASE NOTE: this wiring scheme is a non-binding policy, it may be incorrect due to changes in connected hardware. So in every case please check this table against specification and wiring documentation of the used laser!

Variant using E1702S and Digi I/O Extension Board for laser alarms and pilot laser with support for APD index setting via DB-25 serial data interface

| Signal Name              | Board                    | Connector / Pin                   | IPG Pin              |
|--------------------------|--------------------------|-----------------------------------|----------------------|
| LP0                      | E1702S Baseboard         | Pin 9                             | Pin 1                |
| LP1                      |                          | Pin 11                            | Pin 2                |
| LP2                      |                          | Pin 13                            | Pin 3                |
| LP3                      |                          | Pin 15                            | Pin 4                |
| LP4                      |                          | Pin 17                            | Pin 5                |
| LP5                      |                          | Pin 19                            | Pin 6                |
| LP6                      |                          | Pin 21                            | Pin 7                |
| LP7                      |                          | Pin 23                            | Pin 8                |
| LP8 Latch                |                          | Pin 25                            | Pin 9                |
| MO / Main Oscillator     |                          | Pin 18                            | Pin 18               |
| LaserA / Frequency       |                          | Pin 22                            | Pin 20               |
| Laser Gate / Modulation  |                          | Pin 20                            | Pin 19               |
| Pilot                    |                          | Pin 16                            | Pin 22 <sup>1)</sup> |
|                          |                          |                                   |                      |
| Alarm, one of DIn0..DIn7 | Digi I/O Extension Board | Pin 4, 6, 8, 10, 12, 14, 16 or 18 | Pin 16               |
| Alarm, one of DIn0..DIn7 |                          | Pin 4, 6, 8, 10, 12, 14, 16 or 18 | Pin 21               |
| Serial Enable            |                          | Pin 7                             | Pin 24               |
| Serial Clock             |                          | Pin 9                             | Pin 13               |
| Serial Data              |                          | Pin 11                            | Pin 10               |



<sup>1)</sup> may require additional power driver since some laser variants consume a current at this input which is higher than the maximum output allowed

In this wiring-scheme no GND-connections are listed, they have to be added in order to get valid and working connections.

## Wiring between E1702S and IPG YLP Series Type F fiber laser



PLEASE NOTE: this wiring scheme is a non-binding policy, it may be incorrect due to changes in connected hardware. So in every case please check this table against specification and wiring documentation of the used laser!

| Signal Name               | Board                   | E1702 Connector / Pin             | D-SUB25 |
|---------------------------|-------------------------|-----------------------------------|---------|
| LP0                       | E1702S Baseboard        | Pin 9                             | Pin 1   |
| LP1                       |                         | Pin 11                            | Pin 2   |
| LP2                       |                         | Pin 13                            | Pin 3   |
| LP3                       |                         | Pin 15                            | Pin 4   |
| LP4                       |                         | Pin 17                            | Pin 5   |
| LP5                       |                         | Pin 19                            | Pin 6   |
| LP6                       |                         | Pin 21                            | Pin 7   |
| LP7                       |                         | Pin 23                            | Pin 8   |
| LP8 Latch                 |                         | Pin 25                            | Pin 9   |
| MO / Main Oscillator      |                         | Pin 18                            | Pin 18  |
| LaserA / Frequency        |                         | Pin 22                            | Pin 20  |
| Laser Gate / Modulation   |                         | Pin 20                            | Pin 19  |
| Pilot                     |                         | Pin 16                            | Pin 22  |
| GND                       |                         | Pin 10                            | Pin 14  |
|                           |                         |                                   |         |
| Alarm, one of DIn0...DIn7 | Digi IO Extension Board | Pin 4, 6, 8, 10, 12, 14, 16 or 18 | Pin 11  |
| Alarm, one of DIn0...DIn7 |                         | Pin 4, 6, 8, 10, 12, 14, 16 or 18 | Pin 16  |
| Alarm, one of DIn0...DIn7 |                         | Pin 4, 6, 8, 10, 12, 14, 16 or 18 | Pin 21  |

## Wiring between E1702S and Raycus fiber laser



PLEASE NOTE: this wiring scheme is a non-binding policy, it may be incorrect due to changes in connected hardware. So in every case please check this table against specification and wiring documentation of the used laser!

Variant using E1702S and optional Digi I/O Extension Board for laser alarms.

| Signal Name                  | Board                       | Connector / Pin                   | Raycus DB25 Pin |
|------------------------------|-----------------------------|-----------------------------------|-----------------|
| LP0                          | E1702S Baseboard            | Pin 9                             | Pin 1           |
| LP1                          |                             | Pin 11                            | Pin 2           |
| LP2                          |                             | Pin 13                            | Pin 3           |
| LP3                          |                             | Pin 15                            | Pin 4           |
| LP4                          |                             | Pin 17                            | Pin 5           |
| LP5                          |                             | Pin 19                            | Pin 6           |
| LP6                          |                             | Pin 21                            | Pin 7           |
| LP7                          |                             | Pin 23                            | Pin 8           |
| MO / Main Oscillator         |                             | Pin 18                            | Pin 18          |
| LaserA / Frequency           |                             | Pin 22                            | Pin 20          |
| Laser Gate / Modulation      |                             | Pin 20                            | Pin 19          |
|                              |                             |                                   |                 |
| Alarm,<br>one of DIn0...DIn7 | Digi I/O Extension<br>Board | Pin 4, 6, 8, 10, 12, 14, 16 or 18 | Pin 16          |
| Alarm,<br>one of DIn0...DIn7 |                             | Pin 4, 6, 8, 10, 12, 14, 16 or 18 | Pin 21          |

In this wiring-scheme no GND-connections are listed, they have to be added in order to get valid and working connections.

## Wiring between E1702S and MaxPhotonics MFP fiber laser



PLEASE NOTE: this wiring scheme is a non-binding policy, it may be incorrect due to changes in connected hardware. So in every case please check this table against specification and wiring documentation of the used laser!

Variant using E1702S and optional Digi I/O Extension Board for laser alarms.

| Signal Name                  | Board                    | E1702x Pin                        | MaxPhotonics DB25 Pin |
|------------------------------|--------------------------|-----------------------------------|-----------------------|
| LP0                          | E1702S Baseboard         | Pin 9                             | Pin 1                 |
| LP1                          |                          | Pin 11                            | Pin 2                 |
| LP2                          |                          | Pin 13                            | Pin 3                 |
| LP3                          |                          | Pin 15                            | Pin 4                 |
| LP4                          |                          | Pin 17                            | Pin 5                 |
| LP5                          |                          | Pin 19                            | Pin 6                 |
| LP6                          |                          | Pin 21                            | Pin 7                 |
| LP7                          |                          | Pin 23                            | Pin 8                 |
| LP8 Latch                    |                          | Pin 25                            | Pin 9                 |
| MO / Main Oscillator         |                          | Pin 18                            | Pin 18                |
| LaserA / Frequency           |                          | Pin 22                            | Pin 20                |
| Laser Gate / Modulation      |                          | Pin 20                            | Pin 19                |
| Pilot                        |                          | Pin 16                            | Pin 22                |
| GND                          |                          | Pin 10                            | Pin 10-15             |
|                              |                          |                                   |                       |
| Alarm,<br>one of DIn0...DIn7 | Digi I/O Extension Board | Pin 4, 6, 8, 10, 12, 14, 16 or 18 | Pin 16                |
| Alarm,<br>one of DIn0...DIn7 |                          | Pin 4, 6, 8, 10, 12, 14, 16 or 18 | Pin 21                |

In this wiring-scheme no GND-connections are listed, they have to be added in order to get valid and working connections.

## Wiring between E1702S and DAVI D-Series RF CO<sub>2</sub> Laser



PLEASE NOTE: this wiring scheme is a non-binding policy, it may be incorrect due to changes in connected hardware. So in every case please check this table against specification and wiring documentation of the used laser!

Variant using E1702S and optional Digi I/O Extension Board for laser alarm.

| Signal Name                           | Board                    | E1702x Pin                        | DAVI RJ45 Pin | DAVI RJ45 Wire Colour |
|---------------------------------------|--------------------------|-----------------------------------|---------------|-----------------------|
| LaserA / Frequency                    | E1702S Baseboard         | 22                                | 1             | orange/white          |
| GND                                   |                          | 10                                | 8             | brown                 |
|                                       |                          |                                   |               |                       |
| Laser Ready input, one of DIn0...DIn7 | Digi I/O Extension Board | Pin 4, 6, 8, 10, 12, 14, 16 or 18 | 3             | green/white           |
| GND                                   |                          | 2                                 | 6             | green                 |

## Wiring between E1702S and GZTECH S355 series DPSS Laser



PLEASE NOTE: this wiring scheme is a non-binding policy, it may be incorrect due to changes in connected hardware. So in every case please check this table against specification and wiring documentation of the used laser!

Variant using E1701D Baseboard.

| Signal Name        | Board            | E1702S Pin | GZTECH DB9 connector Pin | GZTECH Signal Name |
|--------------------|------------------|------------|--------------------------|--------------------|
| LaserA / Frequency | E1702S Baseboard | 22         | 3                        | PWM                |
| GND                |                  | 10         | 5                        | GND                |
| LaserGate          |                  | 20         | 2                        | Gate               |

Within BeamConstruct following settings have to be done in order to control the laser:

- menu "Project" → "Project settings" → tab-pane "Scanner" → button "Configure" → parameter "Laser type" has to be set to value "YAG1"
- menu "Project" → "Pen settings" → tab-pane "General": the "Frequency" slider has to be set to an appropriate value (typically 30..50 kHz, please refer to the manual of the laser for further details), the "Power" slider has no effect as no additional power output was configured in scanner controller settings
- menu "Project" → "Pen settings" → tab-pane "Laser": the parameter "Pulse length" has to be set to an appropriate value (such as 1 usec, please refer to the manual of the laser for further details)

To use this laser model with BeamConstruct, HALsetup software package version 8.2-07 or newer is required.

# APPENDIX B – E1701D Compatibility Adaptor

The E1701D-adaptor can be used to provide a pinout which is compatible to a E1701D scanner controller card plus its LP8 extension board:

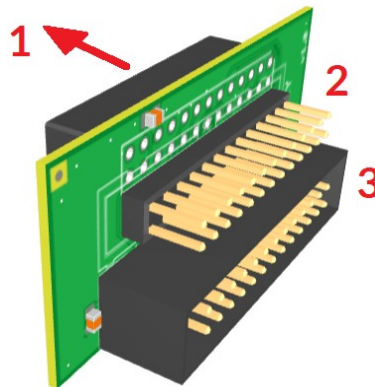

1. Is the connection to the E1702S controller, it has to be plugged into its scanner interface connector directly; please note pin 1 / orientation of the connector!
2. Provides an E1701D-compatible scanner interface pinout:

| Upper Row Of Pins | Signal       | Remarks               | Lower Row Of Pins | Signal       | Remarks               |
|-------------------|--------------|-----------------------|-------------------|--------------|-----------------------|
| 1                 | CLK- / SYNC- | XY2-100 / XY3-100     | 2                 | CLK+ / SYNC+ | XY2-100 / XY3-100     |
| 3                 | SYNC- / CLK- |                       | 4                 | SYNC+ / CLK+ |                       |
| 5                 | X-           |                       | 6                 | X+           |                       |
| 7                 | Y-           |                       | 8                 | Y+           |                       |
| 9                 |              | Not used              | 10                |              | Not used              |
| 11                | LaserA       | Laser control signals | 12                | GND          |                       |
| 13                | Laser Gate   |                       | 14                | GND          |                       |
| 15                | LaserB       |                       | 16                | ExtStart     | Input control signals |
| 17                | 5V           |                       | 18                | ExtStop      |                       |
| 19                |              | do not connect        | 20                | GND          |                       |
| 21                | GND          |                       | 22                | GND          |                       |
| 23                |              | do not connect        | 24                |              | do not connect        |
| 25                |              | Not used              | 26                |              | Not used              |

3. Provides an E1701D-LP8-compatible laser interface pinout:

| Upper Row Of Pins | Signal    | Remarks  | Lower Row Of Pins | Signal    | Remarks                    |
|-------------------|-----------|----------|-------------------|-----------|----------------------------|
| 1                 | LP8_0     |          | 2                 | GND       |                            |
| 3                 | LP8_1     |          | 4                 | Pilot     | Pilot-laser of E1702       |
| 5                 | LP8_2     |          | 6                 | 5V        |                            |
| 7                 | LP8_3     |          | 8                 | MO        | Main Oscillator            |
| 9                 | LP8_4     |          | 10                |           | Not used                   |
| 11                | LP8_5     |          | 12                |           |                            |
| 13                | LP8_6     |          | 14                |           |                            |
| 15                | LP8_7     |          | 16                |           |                            |
| 17                | LP8 Latch |          | 18                | 5V        |                            |
| 19                | LaserB    | FPK      | 20                |           | Not used                   |
| 21                |           | Not used | 22                | LaserA    | PWM, frequency or Q-Switch |
| 23                | GND       |          | 24                |           |                            |
| 25                | 5V        |          | 26                | LaserGate |                            |

4.

For details about the E1701D and the LP8 extension, its interfaces and signals, please refer to the related manual from [https://halaser.systems/manuals/e1701\\_manual.pdf](https://halaser.systems/manuals/e1701_manual.pdf)

# APPENDIX C – IDC connector pin numbering

Pin numbering of the IDC connectors (according to pinout-tables shown in hardware description sections above) can be seen in below image:

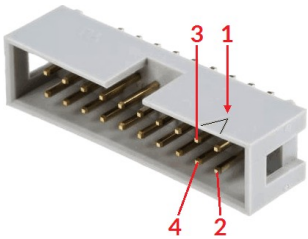

The first pin is marked by a small arrow in connector. Second pin is below of it, counting continues column-wise.

These connectors itself are standard IDC connectors with 2,54 mm contact spacing.

# APPENDIX D – E1702S XY2-100 protocol description

The data submitted at 26 pin connector of E1702S are conform to XY2-100 specification:

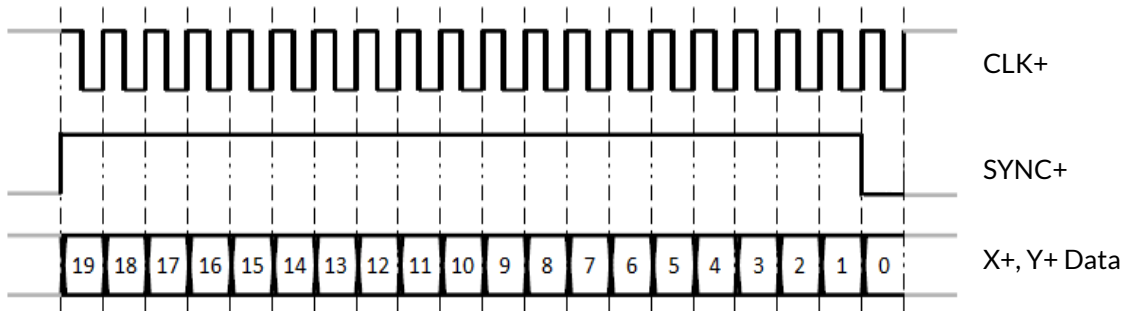

In standard 16 bit operating mode first three bits are set to 001, then 16 bit position data followed by a parity bit (even parity) are transmitted:

|    |    |    |                       |    |    |    |    |    |    |   |   |   |   |   |   |   |   |   |    |
|----|----|----|-----------------------|----|----|----|----|----|----|---|---|---|---|---|---|---|---|---|----|
| 19 | 18 | 17 | 16                    | 15 | 14 | 13 | 12 | 11 | 10 | 9 | 8 | 7 | 6 | 5 | 4 | 3 | 2 | 1 | 0  |
| 0  | 0  | 1  | D15..D0 position data |    |    |    |    |    |    |   |   |   |   |   |   |   |   |   | Pe |

In enhanced XY2-100 18 bit operating mode first bit is set to 1, then 18 bit position data followed by a parity bit (odd parity) are transmitted:

|    |                       |    |    |    |    |    |    |    |    |   |   |   |   |   |   |   |   |    |   |
|----|-----------------------|----|----|----|----|----|----|----|----|---|---|---|---|---|---|---|---|----|---|
| 19 | 18                    | 17 | 16 | 15 | 14 | 13 | 12 | 11 | 10 | 9 | 8 | 7 | 6 | 5 | 4 | 3 | 2 | 1  | 0 |
| 1  | D17..D0 position data |    |    |    |    |    |    |    |    |   |   |   |   |   |   |   |   | Po |   |

To use this mode, the related tune-value has to be set in configuration file (please refer to section “6.1.8 microSD-Card”)

## **APPENDIX E – E1702S XY3-100 protocol description**

Depending on the actual configuration, the data submitted at 26 pin connector of E1702S are conform to XY3-100 specification. For details about the XY3-100 protocol, please check the standard specification from <https://lasia.org/documents.php>.

## **APPENDIX F – E1702S SL2-100 protocol description**

For information about the SL2-100 scanner protocol, please refer to information given online at <https://halaser.systems/compare.php#XY3>

# APPENDIX G – Board dimensions

E1702S board dimension drawings (baseboard plus optional extension boards), all values are given in unit mm.

Connectors, bottom view:

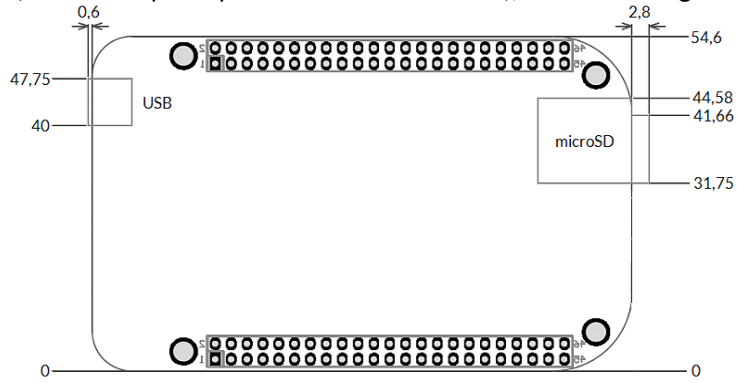

Connectors, top view:

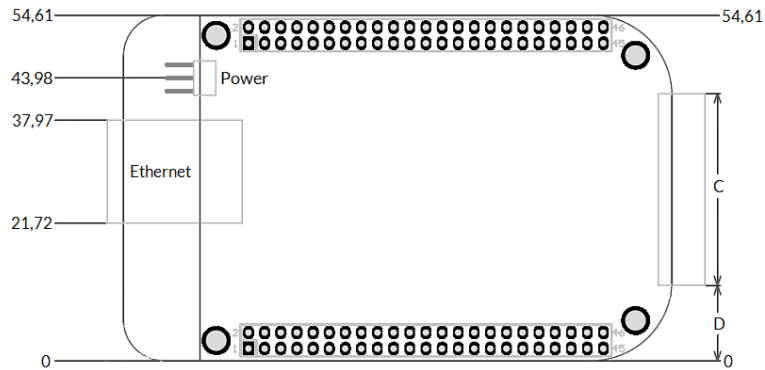

| Board type                     | C     | D       |
|--------------------------------|-------|---------|
| E1702S Baseboard               | 40 mm | 7,3 mm  |
| Digi I/O Extension Board       | 34 mm | 10,3 mm |
| Secondary Head Extension Board | 40 mm | 7,3 mm  |

Dimensions, top view:

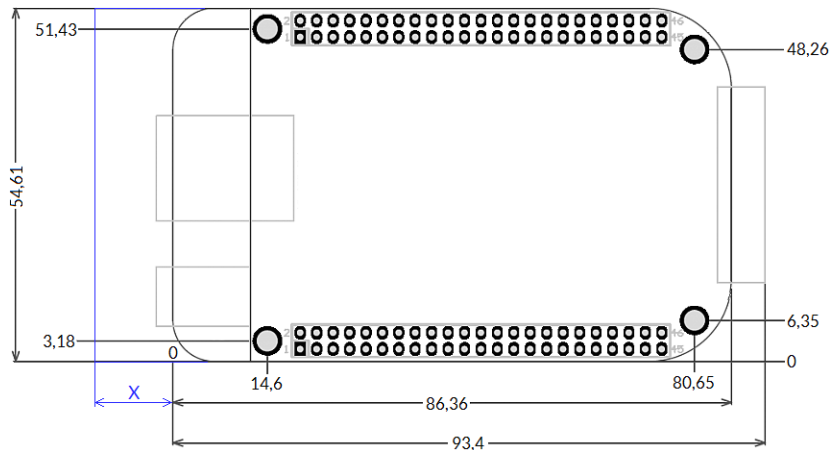

X – for future compatibility leave additional space of 10 mm at Ethernet connector side of the controller

E170Xbase dimension drawing, all values are given in unit mm.

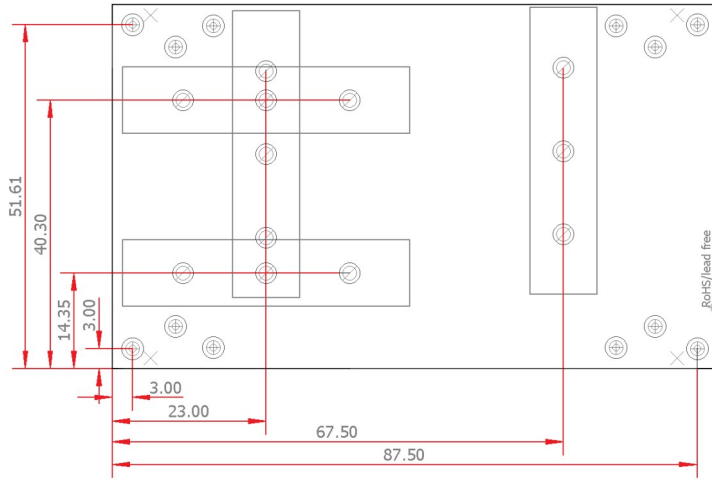

# Index

## 1

16-bit IO port - 24  
18 bit - 23, 115

## 2

2D marking on-the-fly - 39  
2D on-the-fly - 22

## A

Alive - 17  
ASCII - 50  
autofile - 20, 33

## B

BeamConstruct PRO license - 12, 16  
BNC - 45f.  
boot - 25  
Boot - 17

## C

C45 rail - 48  
C45 rail adapter - 48  
C45 rail lock - 48  
cdepr - 53  
cdser - 55  
cecho - 50  
cfror - 54  
cftim - 56  
cgbds - 50  
cgbsr - 51  
cgbuf - 53  
cgcor - 52  
cgepr - 52  
cginp - 58  
cglog - 50  
cgmtx - 54  
cgser - 55  
cgsta - 56  
cgtim - 56  
cgtin - 52  
cgtxt - 57f.  
chalt - 51  
ciser - 55  
cjsor - 20, 53  
clepr - 34, 52, 98  
CLK - 28  
cmsor - 20, 53  
CO2 - 10  
corrtable - 19, 52  
corrtable0 - 19  
cpuor - 54  
cpwor - 20, 54  
crotx - 58  
croty - 58  
crotz - 58  
crrrr - 57  
crser - 55

crtim - 56  
csbuf - 53  
csclx - 58  
cscly - 58  
csclz - 58  
cscor - 19, 52  
csele - 57  
cslgt - 58  
cslmo - 59  
cslp8 - 59  
cslxy - 58  
cslxz - 58  
cslyx - 58  
cslyz - 58  
cslzx - 58  
cslzy - 58  
csmtx - 54f.  
csout - 58  
cspil - 59  
cspof - 55  
csser - 55  
cssta - 22, 57  
cstat - 51, 72  
cstdy - 56  
csthr - 56  
cstim - 55  
cstmi - 56  
cstmo - 56  
cstop - 51  
cstrt - 51  
cstsc - 56  
cstxt - 57f.  
cstyr - 56  
cswaf - 25, 54  
ctrig - 51  
ctrnx - 57  
ctrny - 57  
ctrnz - 57  
cvers - 50  
CW - 10, 26  
cxcnc - 25, 51, 67, 70

## **D**

D-SUB15 - 28  
D-SUB25 - 27f.  
DataMatrix - 101  
DAVI D-Series RF CO2 - 110  
Digi I/O - 43  
digidebc - 21  
digiinit - 21  
digimask - 21  
digital in- and outputs - 36  
dimension drawing - 118  
dimensions - 118  
DIN rail - 48  
DIN/C45 rail adapter - 48  
DIN/C45 rail lock - 48  
Download new firmware - 65  
DYN\_DATA\_MAX\_STRING\_LENGTH - 100f.

## E

e1702.cfg - 18, 73  
e1702.dat - 18  
e1702.fwi - 18  
E1702S - 117  
E170X\_close() - 74, 98f.  
E170X\_COMMAND\_FLAG\_DIRECT - 80, 90ff., 97  
E170X\_COMMAND\_FLAG\_MOTF\_WAIT\_BITS - 94  
E170X\_COMMAND\_FLAG\_MOTF\_WAIT\_INCS - 94  
E170X\_COMMAND\_FLAG\_PASSIVE - 93  
E170X\_COMMAND\_FLAG\_SCANNER\_VAR\_POLYDELAY - 78  
E170X\_COMMAND\_FLAG\_STREAM - 80, 90ff., 97  
E170X\_COMMAND\_FLAG\_SYNC - 86  
E170X\_COMMAND\_FLAG\_WRITE\_LASERA\_GPO - 98  
E170X\_COMMAND\_FLAG\_WRITE\_LASERB\_GPO - 98  
E170X\_COMMAND\_FLAG\_WRITE\_LASERGATE - 98  
E170X\_COMMAND\_FLAG\_WRITE\_LP8LATCH - 98  
E170X\_COMMAND\_FLAG\_WRITE\_LP8MO - 98  
E170X\_COMMAND\_FLAG\_XYCORR\_MIRRORX - 75  
E170X\_COMMAND\_FLAG\_XYCORR\_MIRROR - 75  
E170X\_CSTATE\_FILE\_WRITE\_ERROR - 87  
E170X\_CSTATE\_HALTED - 87  
E170X\_CSTATE\_MARKING - 87  
E170X\_CSTATE\_PROCESSING - 87  
E170X\_CSTATE\_SAC\_CTLXY - 88  
E170X\_CSTATE\_SAC\_MARKING - 88  
E170X\_CSTATE\_SAC\_READY - 88  
E170X\_CSTATE\_WAIT\_EXTTRIGGER - 87  
E170X\_CSTATE\_WAIT\_INPUT - 87  
E170X\_CSTATE\_WAS\_START\_PRESSED - 87  
E170X\_CSTATE\_WAS\_STOP\_PRESSED - 87  
E170X\_CSTATE\_WRITING\_DATA - 65  
E170X\_CSTATE\_WRITING\_DATA\_ERROR - 65  
E170X\_delay() - 88, 94  
E170X\_digi\_pulse() - 92  
E170X\_digi\_read() - 93  
E170X\_digi\_set\_mip\_output() - 20, 94  
E170X\_digi\_set\_motf\_sim() - 94  
E170X\_digi\_set\_motf\_sim() - 94  
E170X\_digi\_set\_motf() - 93f.  
E170X\_digi\_set\_wet\_output() - 21, 95  
E170X\_digi\_wait\_motf() - 94  
E170X\_digi\_wait() - 93  
E170X\_digi\_write() - 92  
E170X\_digim\_move\_abs() - 96  
E170X\_digim\_move\_rel() - 97  
E170X\_digim\_set\_accels() - 96  
E170X\_digim\_set\_limits() - 96  
E170X\_digim\_set\_pos() - 97  
E170X\_digim\_set\_speed() - 96f.  
E170X\_dynamic\_data2() - 98f.  
E170X\_ERROR - 103  
E170X\_ERROR\_BORD\_NA - 92, 96, 102  
E170X\_ERROR\_FILENAME - 103  
E170X\_ERROR\_FILEOPEN - 102  
E170X\_ERROR\_FILEWRITE - 102  
E170X\_ERROR\_INVALID\_CARD - 102  
E170X\_ERROR\_INVALID\_DATA - 102  
E170X\_ERROR\_NO\_CONNECTION - 102

E170X\_ERROR\_NO\_MEMORY - 102  
E170X\_ERROR\_NOT\_SUPPORTED - 103  
E170X\_ERROR\_STILL\_IN\_PROGRESS - 103  
E170X\_ERROR\_TRANSMISSION - 102  
E170X\_ERROR\_UNKNOWN\_BOARD - 103  
E170X\_ERROR\_UNKNOWN\_FW - 102  
E170X\_execute() - 73, 85f.  
E170X\_FILEMODE\_LOCAL - 98f.  
E170X\_FILEMODE\_SEND - 98f.  
E170X\_FREE\_SPACE\_PRIMARY - 85, 89  
E170X\_FREE\_SPACE\_SECONDARY - 89  
E170X\_get\_card\_state() - 86f., 95, 97  
E170X\_get\_free\_space() - 73, 85, 89  
E170X\_get\_library\_version() - 90  
E170X\_get\_pos() - 82  
E170X\_get\_serial\_number() - 90  
E170X\_get\_startstop\_state() - 86  
E170X\_get\_sync() - 85  
E170X\_get\_version() - 90  
E170X\_halt\_execution() - 86f.  
E170X\_jump\_abs() - 80, 94  
E170X\_LASERMODE\_CO2 - 78  
E170X\_LASERMODE\_CRF - 79  
E170X\_LASERMODE\_DFREQ - 79, 89  
E170X\_LASERMODE\_MOPA - 70, 80  
E170X\_LASERMODE\_YAG1 - 78  
E170X\_LASERMODE\_YAG2 - 79  
E170X\_LASERMODE\_YAG3 - 79, 89  
E170X\_load\_correction() - 73f., 99  
E170X\_lp8\_write\_latch() - 91  
E170X\_lp8\_write\_mo() - 91  
E170X\_lp8\_write\_pilot() - 91  
E170X\_lp8\_write() - 90  
E170X\_mark\_abs() - 81, 94  
E170X\_mark\_pixelline() - 83f.  
E170X\_OK - 102  
E170X\_PIXELMODE\_GATE\_POWER\_CONTROL - 83  
E170X\_PIXELMODE\_HW\_POWER\_CONTROL - 83  
E170X\_PIXELMODE\_JUMP\_LEAVE\_POWER - 83  
E170X\_PIXELMODE\_JUMP\_N\_SHOOT - 83  
E170X\_PIXELMODE\_NO\_JUMPS - 83  
E170X\_power\_callback - 84  
E170X\_release\_trigger\_point() - 84f., 89, 94  
E170X\_set\_connection() - 73, 82, 97ff.  
E170X\_set\_debug\_logfile() - 75  
E170X\_set\_filepath() - 98f.  
E170X\_set\_fpk() - 89  
E170X\_set\_laser\_delays() - 77, 83  
E170X\_set\_laser\_mode() - 78  
E170X\_set\_laser\_timing() - 88  
E170X\_set\_laser() - 80  
E170X\_set\_laserb() - 79, 89  
E170X\_set\_matrix() - 75, 84  
E170X\_set\_overspeed() - 77  
E170X\_set\_password() - 19, 73  
E170X\_set\_pixelmode() - 82  
E170X\_set\_pos() - 82  
E170X\_set\_scanner\_delays - 78  
E170X\_set\_scanner\_delays() - 78  
E170X\_set\_speeds() - 76

E170X\_set\_standby() - 88  
E170X\_set\_sync() - 85  
E170X\_set\_trigger\_point() - 73, 84f., 94  
E170X\_set\_wobble() - 80  
E170X\_set\_xy\_correction() - 75  
E170X\_set\_xy\_correction2() - 84  
E170X\_set\_z\_correction() - 75  
E170X\_stop\_execution() - 86  
E170X\_switch\_correction() - 74  
E170X\_write() - 97  
electrically insulated - 36  
electrostatic sensitive device - 9  
enhanced XY2-100 - 23, 115  
EPR - 30, 52f.  
Error - 18  
ESD - 9  
eth - 24  
Ethernet - 10, 13ff., 19, 24f.  
extension - 29  
ExtStart - 45, 84f., 95  
ExtStop - 45, 86

## **F**

fiber laser - 105  
Firmware - 25  
FPK - 10, 45, 113

## **G**

G-Code - 51  
G0 - 68, 70  
G1 - 68, 70  
G2 - 68  
G3 - 68  
G4 - 68  
G70 - 70  
G71 - 70  
g718 - 1  
gateway - 24  
GRBL - 71  
grid correction - 10  
GZTECH S355 series DPSS - 111  
GZTech YFPN - 44, 104

## **H**

HALnode Compact Ethernet IO - 24  
haltedloop - 20, 33  
haltedlooptimeout - 20, 33

## **I**

idxselect - 20, 34, 52f.  
in-polygon delay - 78  
iobuff - 20, 34, 53  
iohaltedloop - 20, 33f., 52f.  
iolatch - 19, 34  
ioselect - 20, 30, 33ff., 52f.  
iothres - 20  
IP - 13, 19  
ip0 - 19  
IPG - 10, 44  
IPG YLP - 44, 104ff.

## **J**

JPT - 44  
JPT YDFLP - 44, 105  
jump delay - 78, 80

## **L**

Laser LED - 18  
Laser LEDs - 13  
laser off delay - 81  
laser on delay - 81  
LaserA - 113  
LaserB - 113  
lasergate - 21  
Latch - 26f., 113  
LED - 17  
load\_correction\_file() - 74  
loop - 33  
LP8 - 23, 26f.

## **M**

M2 - 51, 69  
M3 - 69  
M5 - 69  
M704 - 68  
M707 - 70  
M709 - 68ff.  
M715 - 69  
m718 - 1  
M718 - 69  
machine network - 13  
main oscillator - 23  
mark delay - 78, 81  
Marking Active - 18  
marking on-the-fly - 11, 36f.  
Marking On-The-Fly - 38  
Master Oscillator - 10, 113  
MaxPhotonics - 44, 109  
MaxPhotonics MFP - 44, 109  
MFP - 44  
Micro-SD - 18  
Micro-SD-card - 13  
Micro-SD-Card - 18  
microUSB - 16  
mipout - 20  
MO - 23, 113  
MOPA - 44, 105  
MOPA alarm - 45

## **N**

n\_load\_correction\_file() - 74  
netmask - 24  
node0 - 24  
node1 - 24  
NOTE - 13  
NTP - 23  
NX-02 - 10, 13, 27, 41

## **O**

Opto-Configuration - 36, 39

opto-insulated - 37

## **P**

passwd - 19

pethd - 25

polydelay - 78

Power - 13

Power LED - 13, 17f.

Power supply - 17

PWM - 45, 113

PWM frequency - 10

## **Q**

Q-Switch - 10, 113

quadrature encoder - 11

## **R**

Raycus - 44, 108

Raycus RFL-PMX - 44

Raycus RFL-PQB - 44

Reset - 13, 18

RFL-PMX - 44

RFL-PQB - 44

## **S**

ScSCIIInitInterface() - 74

SL2-100 - 117

SNTP - 23

Stand-Alone - 32

Stand-Alone Control - 35

standalone - 19

Stop - 18

SYNC - 28

## **T**

T1 - 69, 71

tune - 21

tunemarkout - 21ff., 35

tunereadyout - 21ff., 35

Type B - 104

Type D - 105

Type E - 106

Type F - 107

## **U**

USB - 13

USB 2.0 - 10

User LEDs - 13

## **V**

value - 97

## **W**

wetout - 21

Windows - 14f.

## **X**

XY2-100 - 10, 44

XY2/100 - 13, 27f.

XY3-100 - 10, 13, 23, 26, 28, 44, 116

## Y

YAG - 10

YAG/CO2 - 45

YDFLP - 44

YLP - 44

▪

.bco - 74

.crt - 74

.ct5 - 74

.ctb - 74

.fcr - 74

.gcd - 74

.txt - 74

.ucf - 74

.xml - 74